

# T2

Integrated Multi Axis Turning Center





# PROCESS-INTEGRATED MULTI AXIS TURNING CENTER

T2 can handle a variety of complex processes, from turning to milling in one setting. With optional available second main spindle, optional two longitudinal turrets and Y-axis, the T2-series turning center can be specifically configured in 8 different combinations. The T2-series turning center will reduce your down time and increase your machining efficiency drastically make your work precise and productive.

1 Turbine Blade / SAMPLE / AL6061   2 Tool Holder / Machine Tool Industry / SKD11  
3 Spider / Automobile / 20CrNiMo6   4 Valve / Semiconductor / SCW410

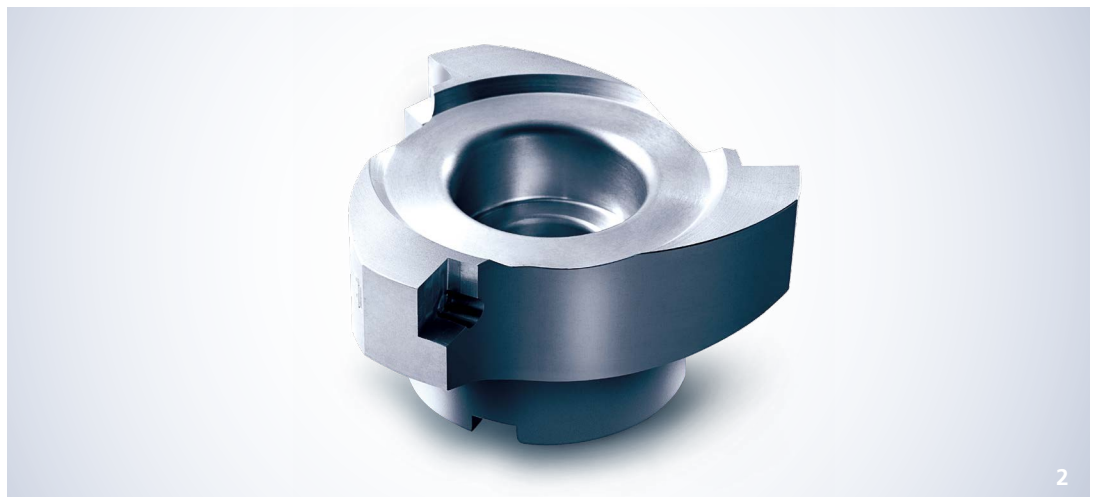

# MULTI AXIS PROCESS-INTEGRATED PRODUCTION TURNING CENTER

T2 incorporates the new symmetry "Box-on-Box" module design to eliminate thermal extensions and to limit thermal displacement to a workpiece. The highly rigid main spindle, turret with integrated motors to minimize vibration, noise and power loss and to ensure best process performance. The secondary spindle and turret provide same performance and specifications as the primary units, To achieve best and most stable operations all guide-ways using Linear Roller guides. The added Y-axis and the powerful milling capability allow for process-integrated machining with a relatively small footprint at highest flexibility.



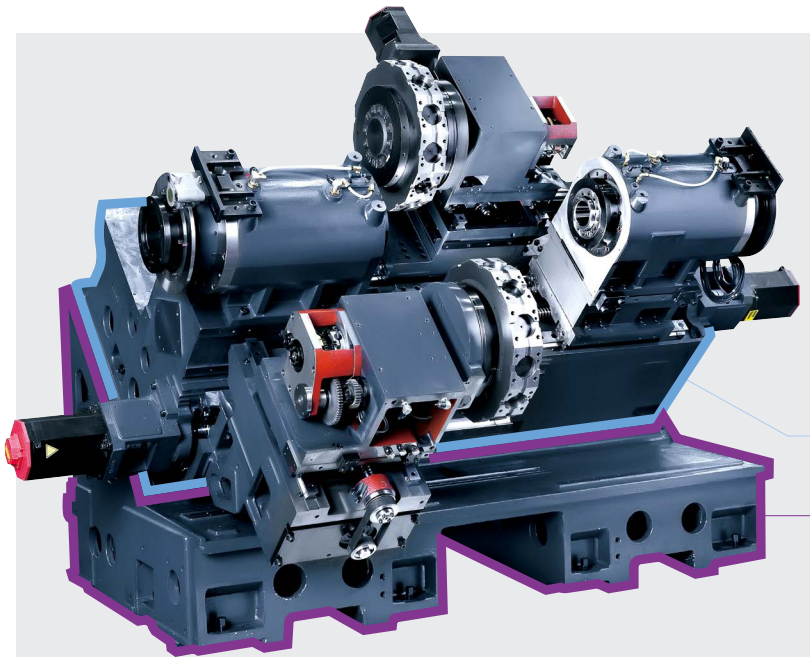

**The new thermal symmetrical design**

T2 incorporates the new "Box-on-Box" module thermal symmetrical design to eliminate thermal and to limit thermal displacement of a workpiece. The machine components are symmetrically mounted on the one piece machine base to ensure even distribution of heat, each module is slanted against each other at 45 degrees, ensuring vibration-free machining at all speeds.

○ Box 1

○ Box 2

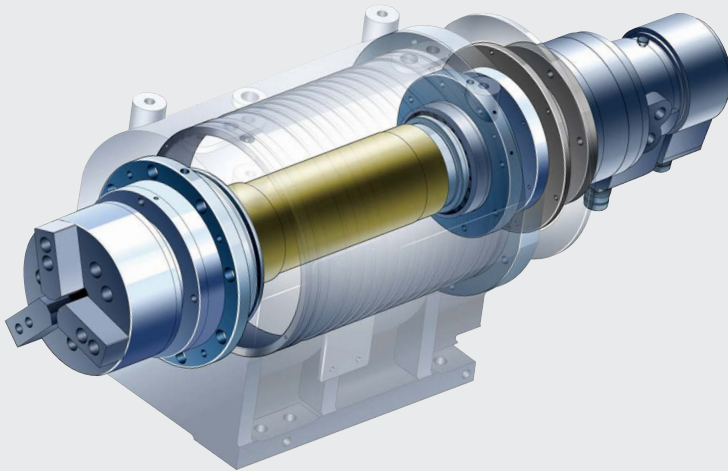

**Highly rigid spindle  
Turret with built-in motors**

The spindle and turret are standard with an efficient cooling system using oil-jacket circulation system for minimized thermal distortion. The turret uses built-in motors to limit noise, vibration and power loss. The secondary spindle and second available turret provide the same performance and specifications as the primary units to achieve equal operation performances.

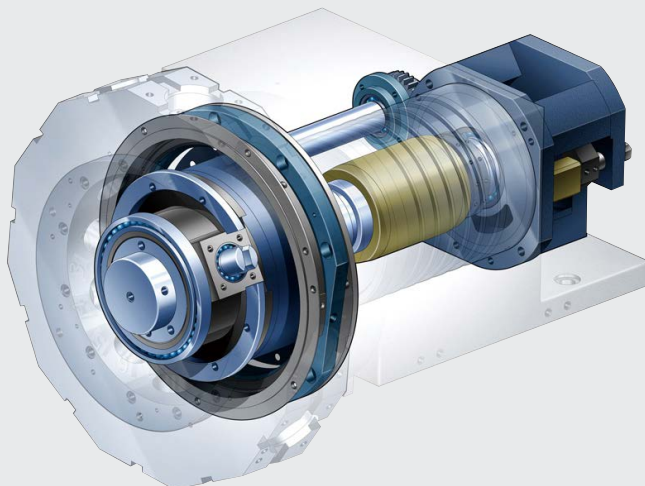

### | Turret 1 |

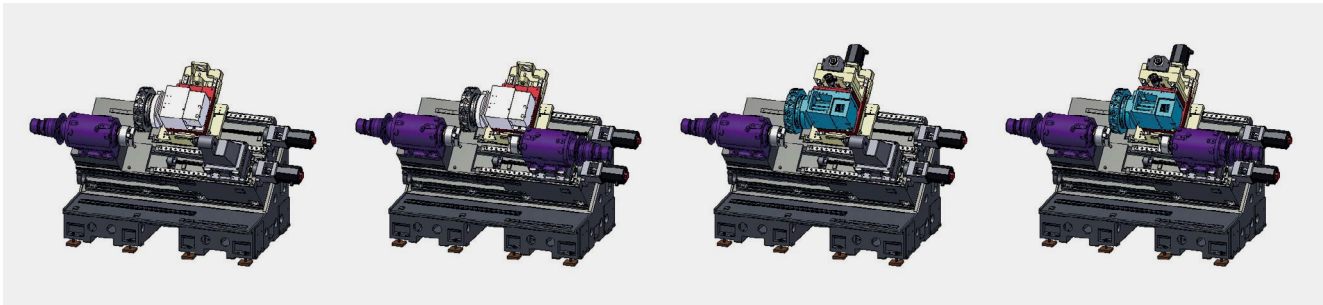

T2-1TMC

T2-1TSMC

T2-1TYMC

T2-1TYSMC

### | Turret 2 |

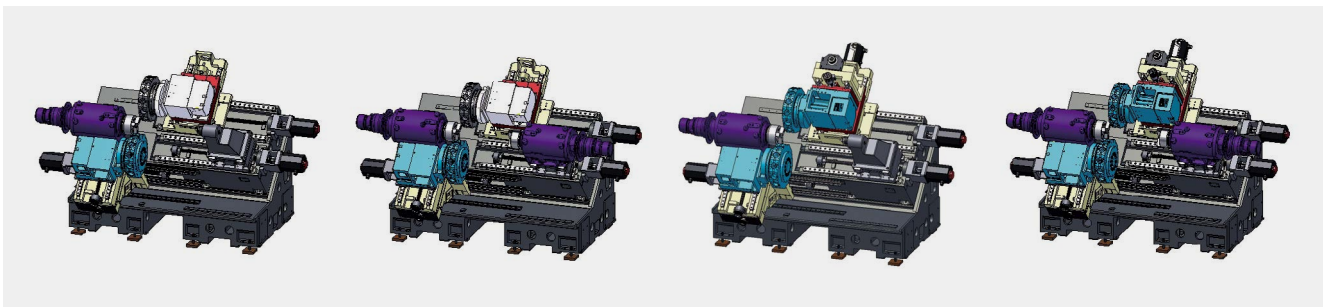

T2-2TMC

T2-2TSMC

T2-2TYMC

T2-2TYSMC

#### Configure your own machine combination

The T2-series can be used in 8 different combination so you can configure your T2 according to your machining requirements. All machine specifications are built on the same compact base structure with the same exterior dimensions to optimize your floor space.

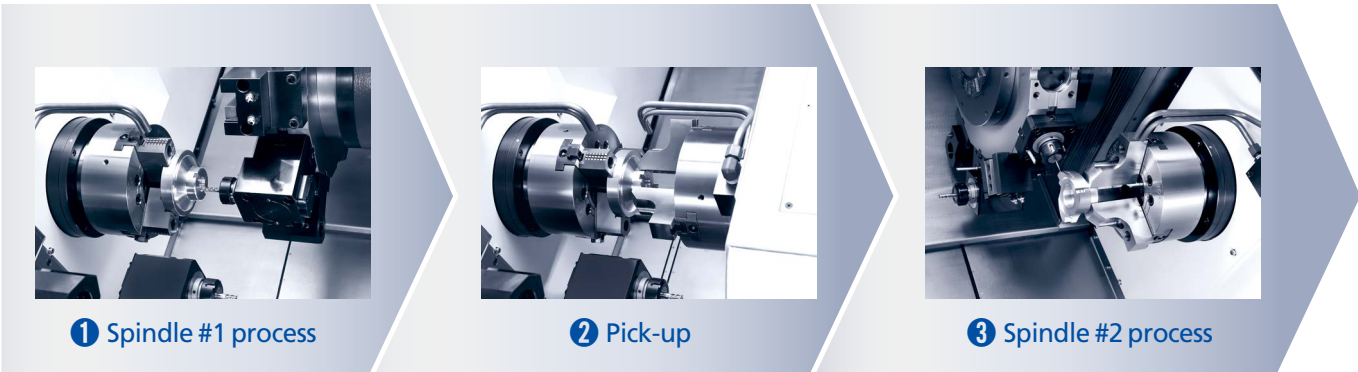

1 Spindle #1 process

2 Pick-up

3 Spindle #2 process

#### Option: Secondary spindle

With the addition of the secondary spindle, the main and the secondary spindles work in sync to complete the first and second operation of your process, to ensure your work is highly productive.

#### Make any forms and shapes with process integration

Control multiple axes simultaneously using the Turnmill function and spindle C-axis indexing.



# USER FRIENDLY DESIGN, A WIDE RANGE OF OPTIONAL FEATURES

T2 is designed with the end user in mind. Its user-friendly machine design and a variety of supplementary features made for stronger, faster and more precise machining performances.

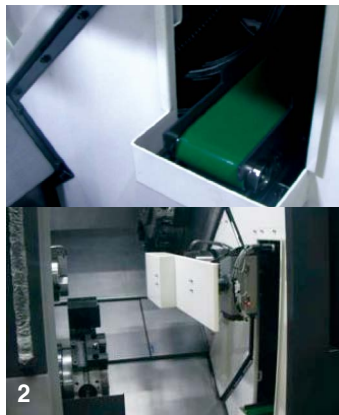
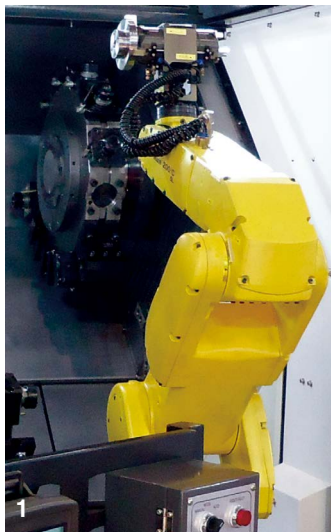

## 1. The workpiece handling system by robot(Option)

The robot system is an excellent add-on which automatically loads & unloads workpieces safely to reduce down-time. Ideal for automatic and operator free operations.

## 2. Part catcher and work conveyor(Option)

The part catcher and the work conveyor dispatch either parts or left over bar materials after machining to make your operation safer and more time efficient.

### L-HTLD : Hwacheon Lathe Tool Load Detect System (Option)



The Hwacheon Lathe Tool Load Detect System constantly detects and diagnoses the tool load under process to prevent tool wear and damage, and to keep your machine and tools in optimal shape.

#### Load Detection Limit 1

##### Alarm + Feed Hold

> When the LIMIT 1 Alarm sounds, the system holds the feed and the machine goes into standby.

#### Load Detection Limit 2

##### Alarm + Machine Stop

> When the LIMIT 2 Alarm sounds, the system stops the machine, and must be reset to operate it.



Product Data

\* Unit: mm(inch)

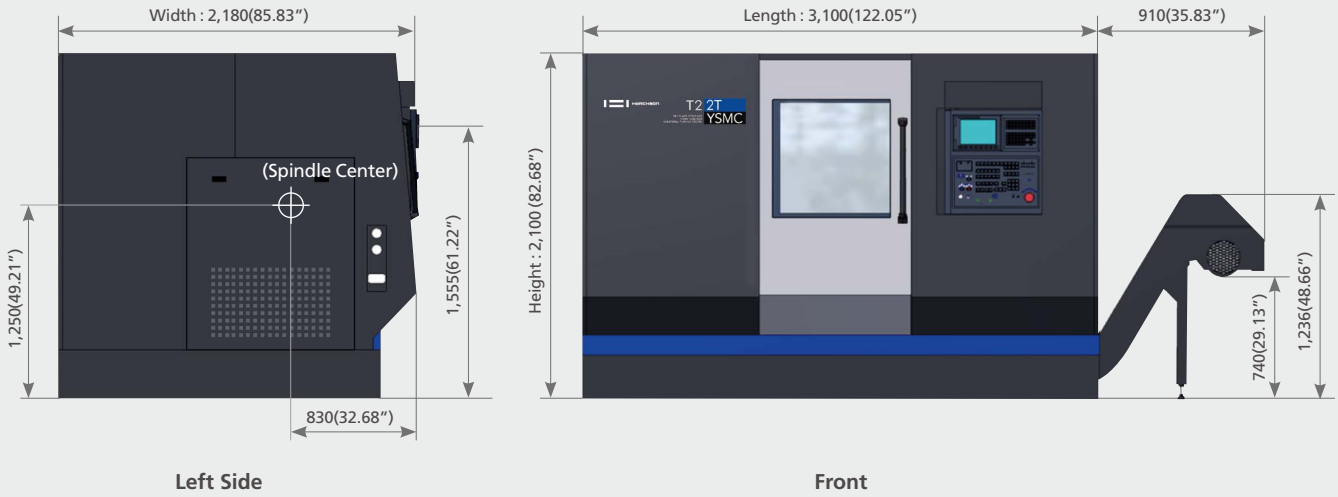

Spindle Power-Torque Diagram

Main Spindle(5,000rpm)

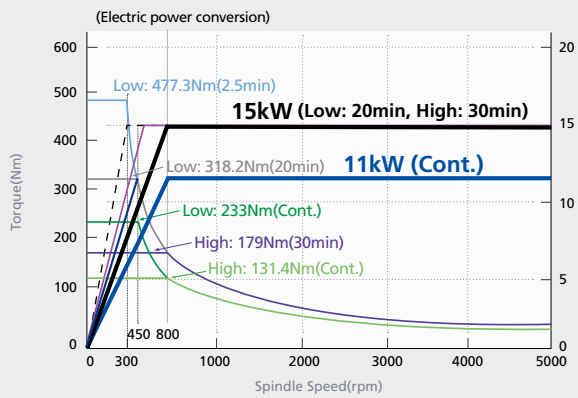

Turnmill Spindle(6,000rpm)

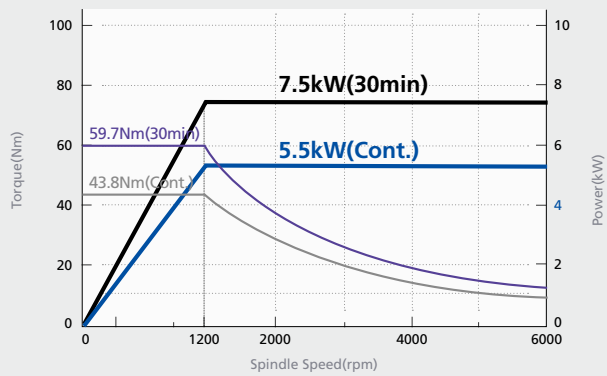

Tool Interference Diagram

※ Unit : mm(inch)

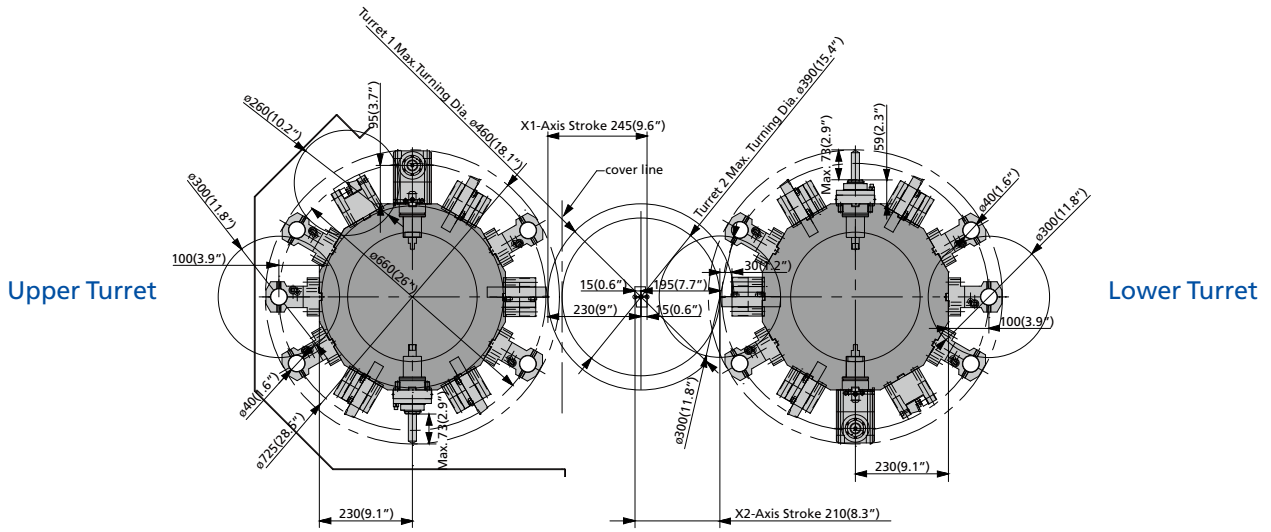

Straight Milling Tool (Y-Axis)

Angular Milling Tool (Y-Axis)

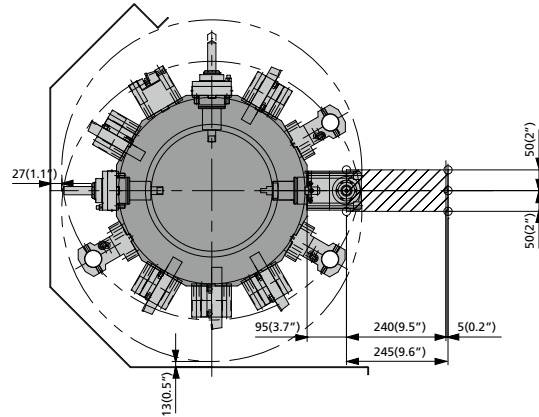
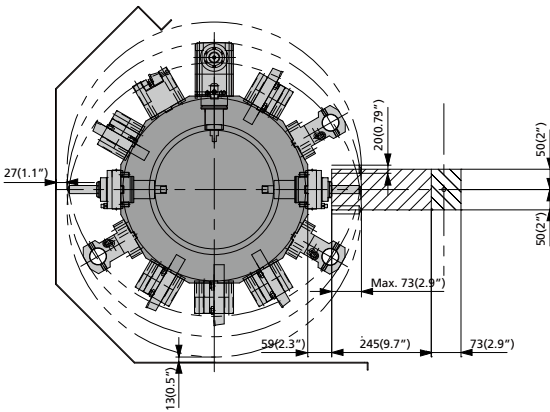

Moving Range

OD Tool

ID Tool

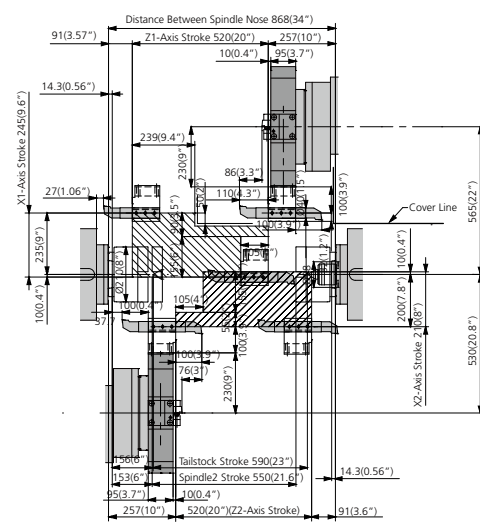
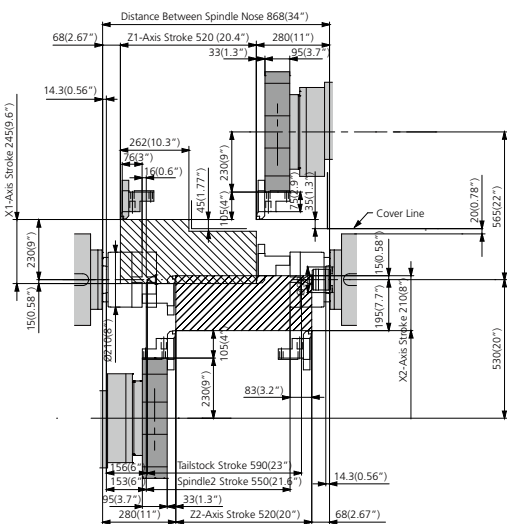

※ Unit : mm(inch)

### Face Tool

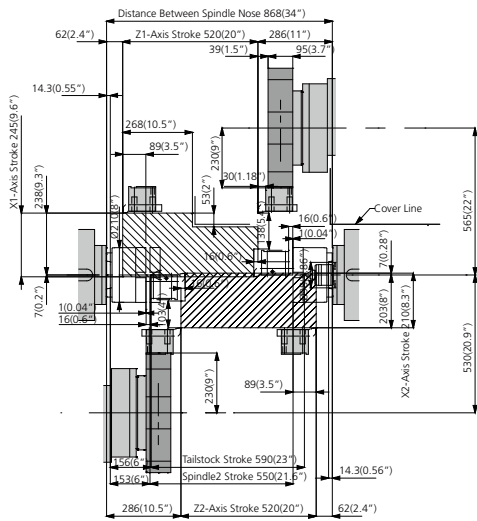

### Angular Milling Tool (Z-Axis)

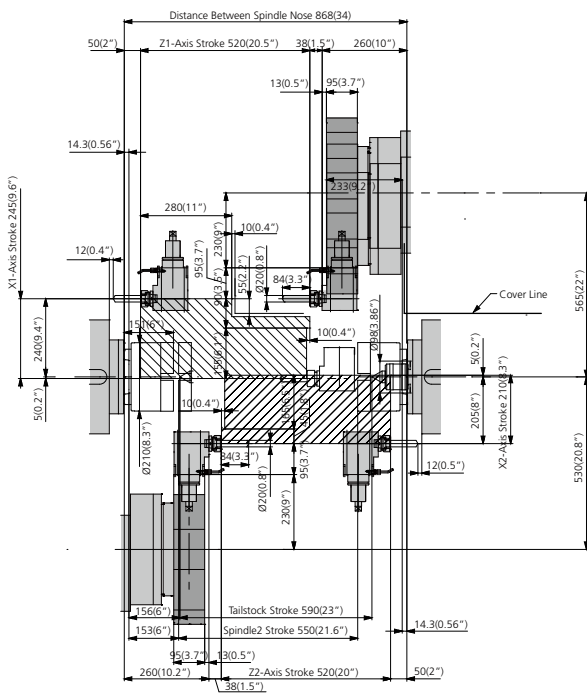

### Straight Milling Tool (X-Axis)

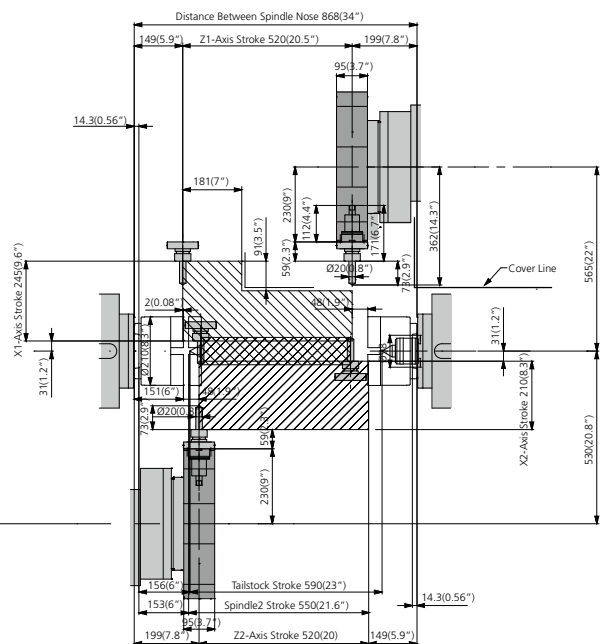

Product Configuration

Each product can be configured to fit your application.

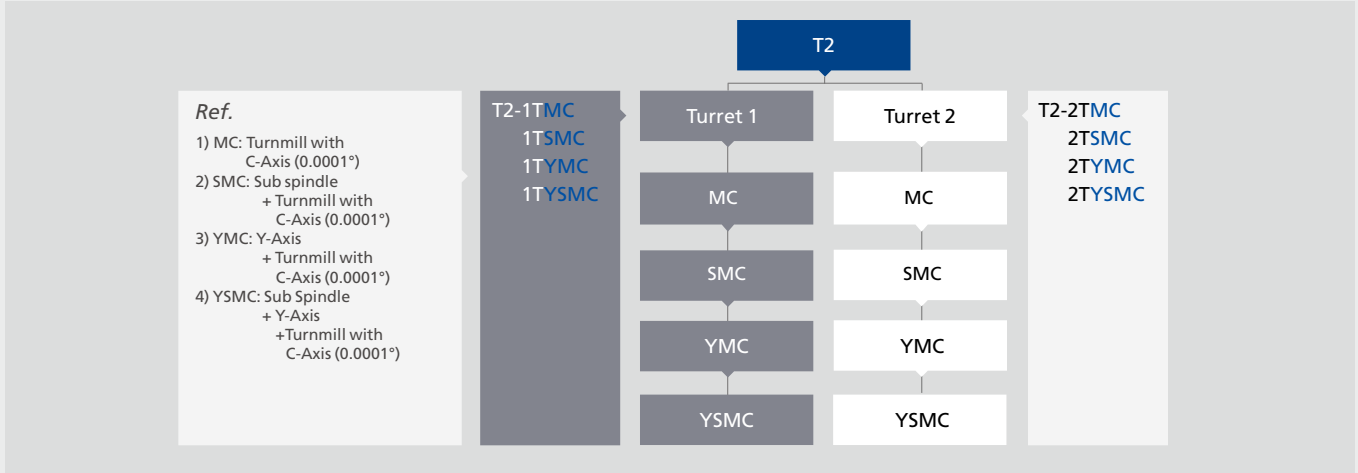

Machine Specifications

ITEM	T2 Series								
	1TMC	1TSMC	1TYMC	1TYSMC	2TMC	2TSMC	2TYMC	2TYSMC	
<b>Capacity</b>									
Swing over Bed	mm(inch)				Ø880 (34.6")				
Max. Cutting Diameter	mm(inch)				Ø460 (18.1")				
Standard Cutting Diameter	mm(inch)				Ø300 (11.8")				
Max. Cutting Length	mm(inch)				444 (17.4")				
Chuck Size (Spindle1 / Spindle2)	inch	8"	8" + 8"	8"	8" + 8"	8"	8" + 8"	8"	8" + 8"
<b>Spindle (Spindle1 &amp; Spindle2)</b>									
Type of Spindle Nose	ASA				A2-6				
Max. Spindle Speed	rpm				5,000				
Through Spindle Hole Diameter	mm(inch)				Ø76 (Ø3")				
Max. Bar Size	mm(inch)				Ø65 (Ø2.55")				
Spindle Bearing Inner Diameter	mm(inch)				Ø120 (Ø4.72")				
Spindle Motor	kW(HP)				15 / 11 (20 / 15)				
<b>Turret (Turret1 &amp; Turret2)</b>									
Number of Tool Station	ea				12				
Tool Size	mm(inch)				□25 x Ø40 (□1" x Ø1.5")				
Turret Indexing Time	sec/step				0.1				
<b>Axes</b>									
Rapid Speed (X1 / X2 / Z1 / Z2 / Y / B)	m/min(ipm)	X1 : 30 (1181.1) Z1 : 30 (1181.1)	X1 : 30 (1181.1) Z1 : 30 (1181.1) B : 30 (1181.1)	X1 : 30 (1181.1) Z1 : 30 (1181.1) Y : 15 (590.55)	X1 : 30 (1181.1) Z1 : 30 (1181.1) Y : 15 (590.55) B : 30 (1181.1)	X1 : 30 (1181.1) X2 : 30 (1181.1) Z1 : 30 (1181.1) Z2 : 30 (1181.1)	X1 : 30 (1181.1) X2 : 30 (1181.1) Z1 : 30 (1181.1) Z2 : 30 (1181.1) B : 30 (1181.1)	X1 : 30 (1181.1) X2 : 30 (1181.1) Z1 : 30 (1181.1) Z2 : 30 (1181.1) Y : 15 (590.55)	X1 : 30 (1181.1) X2 : 30 (1181.1) Z1 : 30 (1181.1) Z2 : 30 (1181.1) Y : 15 (590.55) B : 30 (1181.1)
Max. Stroke (X1 / X2 / Z1 / Z2 / Y / B)	mm(inch)	X1 : 245 (9.65") Z1 : 520 (20.47")	X1 : 245 (9.65") Z1 : 520 (20.47") B : 550 (21.62")	X1 : 245 (9.65") Z1 : 520 (20.47") Y : 100 (3.94")	X1 : 245 (9.65") Z1 : 520 (20.47") Y : 100 (3.94") B : 550 (21.62")	X1 : 245 (9.65") X2 : 210 (8.27") Z1 : 520 (20.47") Z2 : 520 (20.47")	X1 : 245 (9.65") X2 : 210 (8.27") Z1 : 520 (20.47") Z2 : 520 (20.47") B : 550 (21.62")	X1 : 245 (9.65") X2 : 210 (8.27") Z1 : 520 (20.47") Z2 : 520 (20.47") Y : 100 (3.94")	X1 : 245 (9.65") X2 : 210 (8.27") Z1 : 520 (20.47") Z2 : 520 (20.47") Y : 100 (3.94") B : 550 (21.62")
Feed Motor (X1 / X2 / Z1 / Z2 / Y / B)	kW(HP)	X1 : 3 (4) Z1 : 4 (5.5)	X1 : 3 (4) Z1 : 4 (5.4) B : 4 (5.4)	X1 : 4 (5.4) Z1 : 4 (5.4) Y : 1.6 (2.2)	X1 : 4 (5.4) Z1 : 4 (5.4) Y : 1.6 (2.2) B : 4 (5.5)	X1 : 3 (4) X2 : 3 (4) Z1 : 4 (5.4) Z2 : 4 (5.4)	X1 : 3 (4) X2 : 3 (4) Z1 : 4 (5.4) Z2 : 4 (5.4) B : 4 (5.4)	X1 : 4 (5.4) X2 : 3 (4) Z1 : 4 (5.4) Z2 : 4 (5.4) Y : 1.6 (2.2)	X1 : 4 (5.4) X2 : 3 (4) Z1 : 4 (5.4) Z2 : 4 (5.4) Y : 1.6 (2.2) B : 4 (5.4)
<b>Tailstock</b>									
Quill Dia.	mm(inch)	Ø80 (Ø3.15")	-	Ø80 (Ø3.15")	-	Ø80 (Ø3.15")	-	Ø80 (Ø3.15")	-
Tailstock Body Stroke	mm(inch)	590 (23.23")	-	590 (23.23")	-	590 (23.23")	-	590 (23.23")	-
Quill Taper	MT	# 5	-	# 5	-	# 5	-	# 5	-
<b>Turnmill (Turret1 &amp; Turret2)</b>									
Spindle Motor	kW(HP)	7.5 / 5.5 (10 / 7.5)							
Max. Spindle Speed	rpm	6,000							
Max. Drill/Tap Size	mm(inch)	Ø20 (Ø0.79") x M16							
Min. Index Angle (S1 & S2)	°(deg)	0.0001°							
<b>Tank Capacity</b>									
Lubrication	ℓ (gal)	4 (1.06)							
Hydraulic	ℓ (gal)	60 (16)							
Coolant	ℓ (gal)	260 (69)							
<b>Power Sources</b>									
Electrical Power Supply	kVA	55	75	55	75	65	85	65	85
<b>Dimension</b>									
Height	mm(inch)	2,100 (82.68")							
Floor Space (LxW)	mm(inch)	3,100 x 2,180 (122.05" x 85.83")							
Weight	kg(lb)	7,500 (16,535)	7,700 (16,976)	7,800 (17,196)	8,000 (17,637)	8,800 (19,400)	9,000 (19,842)	9,100 (20,062)	9,500 (20,944)
NC Controller		Fanuc 0i-TF							

## Standard and Optional Product Components

Standard Accessories		Optional Accessories	
• Air Blower (1TSMC / 1TYSMC / 2TSMC / 2TYSMC)	• Signal Lamp with 3 Colors(R,G,Y)	• Air Gun	• Mist Collector
• Coolant System	• Tool Kit & Box	• Air Blower (1TMC / 1TYMC / 2TMC / 2TYMC)	• NC Controller (Funuc 31i-B)
• Cooling System For Spindle & Turret Motor	• Turnmill with C-axis Control 0.0001" of spindle 1	• Auto Door	• NC Cooler
• Door Interlock	• Turnmill with C-axis Control 0.0001" of spindle 2 (In case of SMC Model)	• Bar Feeder Interface	• Oil Skimmer
• Foot Switch	• Turret 12+12 Station (In case of 2T Model)	• Chip Conveyor & Box (Side Type)	• Parts Catcher with Bucket and Part Conveyor (1TMC, 1TYMC)
• Hydraulic Chuck & Cylinder (Big Bore Chuck) (Sp1 - 8", Sp2 - 8" in case of SMC model)	• Work Light	• Chuck Clamp/Unclamp Confirm Switch	• Parts Catcher with Part Conveyor (1TSMC / 1TYSMC / 2TSMC / 2TYSMC)
• Hydraulic Unit 40kg <sub>f</sub> /cm <sup>2</sup>	• 10.4" Color LCD	• Chuck Pressure Check Switch	• Tool & Work Counter, External / Internal
• Leveling Bolt & Plate	• Set of Soft Jaw (SMC Model: 2set)	• Chuck Pressure Compensation	• Tool Life Management
• Lubrication System		• Coolant Gun	• Tool Presetter (Automatic)
• Manual & Parts List		• Dual Pressure (Chuck)	• Transformer
• Manual Guide i		• Dual Pressure (C-axis brake)	• Turnmill Holder (Axial / Radial)
• Servo Tailstock (MT#5) - MC Model		• Set of Hard Jaws - 8"	• U-Drill Holder
		• High Pressure Coolant, 0.6 / 1.5 MPa	• 15" Color LCD (only FANUC)
		• L-HTLD (Lathe-Hwacheon Tool Load Detect)	
		• Linear Scale (X1, X2, Z1, Z2, Y)	

## NC Specifications [Fanuc Oi-TF]

※ - : Not available S : Standard O : Option

ITEM	SPECIFICATION	MC, YMC	SMC, YSMC
<b>Controlled axis</b>			
Controlled axis (Cs axis)	2-Axes Turret 1ea▶ 4/5-axes 6-axes Turret 2ea▶ 6/7-axes 8-axes		
Simultaneously controlled axes	2-Axes 4-axes 4-axes		
Least input increment	0.001mm,0.0001deg,0.0001inch	S	S
Least input increment 1 / 10	0.0001mm, 0.00001inch	O	O
inch/metric conversion	G20, G21	S	S
Stored stroke check 1,2,3		S	S
Chamfering on / off		S	S
Backlash compensation		S	S
<b>Operation</b>			
Automatic & MDI operation		S	S
Program number search		S	S
Sequence number search		S	S
Dry Run, Single Block		S	S
Manual handle feed	1Unit	S	S
Manual handle feed rate	x1, x10, x100	S	S
<b>Interpolation function</b>			
Positioning	G00	S	S
Linear interpolation	G01	S	S
Circular interpolation	G02, G03	S	S
Dwell (Per seconds)	G04	S	S
Polar coordinate interpolation	G12.1 / G13.1	S	S
Cylindrical interpolation	G7.1	S	S
Threading	G32	S	S
Multiple threading		S	S
Threading retract		S	S
Continuous threading		S	S
Variable lead threading	G34	S	S
Reference position return 1st	G28	S	S
Reference position return check	G27	S	S
2,3,4th reference position return	G30	S	S
<b>Feed function</b>			
Rapid traverse override	F0, F25, F50, F100	S	S
Feed per minute (mm/min)	G98	S	S
Feed per revolution (mm/rev)	G99	S	S
Rapid traverse bell-shaped acceleration/deceleration		S	S
Feedrate override	0 - 150%	S	S
Jog feed override	0 - 1,260 mm/min	S	S
<b>Tool function / compensation</b>			
Tool function	T4-digits	S	S
Tool offset pairs	128pairs	S	S
Tool nose radius compensation		S	S
Tool geometry/wear compensation		S	S
Tool life management		O	O
Automatic tool offset	Tool presetter option is required	S	S
Direct input tool offset value measured B	Tool presetter option is required	S	S
<b>Others</b>			
Display unit	10.4" Color LCD	S	S

ITEM	SPECIFICATION	MC, YMC	SMC, YSMC
<b>Program input</b>			
Programmable data input	G10	S	S
Sub program call	10 folds Nested	S	S
Custom Macro B		S	S
Addition of custom macro -common variables	#100 - #199, #500 - #999	S	S
Canned cycles		S	S
Multiple repetitive cycle		S	S
Multiple repetitive cycle II		S	S
Canned cycles for drilling		S	S
Manual Guide i		S	S
Tape code	EIA / ISO	S	S
Optional block skip	9ea	S	S
Program number	O4 - digits	S	S
Sequence number	N8 - digits	S	S
Decimal point programming		S	S
Coordinate system setting	G50	S	S
Coordinate system shift		S	S
Workpiece coordinate system	G54 - G59	S	S
Workpiece coordinate system preset	G92.1	S	S
Direct drawing dimension programming		S	S
G code system	A	S	S
<b>Spindle speed function</b>			
Constant surface speed control	G96 / G97	S	S
Spindle override	50 - 120%	S	S
Spindle orientation		S	S
Rigid tapping		S	S
Spindle synchronous control		-	S
<b>Editing operation</b>			
Part program storage length	1,280m (512kB)	S	S
Number of register able programs	400ea	S	S
Background editing		S	S
Extended part program editing		S	S
Play Back		S	S
<b>Operation / Display</b>			
Clock function		S	S
Self-diagnosis function		S	S
Alarm history display		S	S
Help function		S	S
Run hour and parts count display		S	S
Graphic function		S	S
Dynamic graphic display		O	O
Multi-language display	English, German, French, Italian, Chinese, Spanish, Korean, Portuguese, Polish, Hungarian, Swedish, Russian	S	S
<b>Data input / output</b>			
Reader / Puncher interface CH1	RS232C	S	S
Reader / Puncher interface CH2	RS232C	S	S
Ethernet interface		S	S
Memory card interface		S	S
USB card interface		S	S

## Hwacheon Global Network

 Hwacheon Headquarter  Hwacheon America  Hwacheon Europe  Hwacheon Asia



**HWACHEON**

Please contact us for product inquiries.

[www.hwacheon.com](http://www.hwacheon.com)

The product design and specifications may change without prior notice.  
Read the operation manual carefully and thoroughly before operating the product,  
and always follow the safety instructions and warnings labels attached on the surfaces of the machines.

### HEAD OFFICE

#### HWACHEON MACHINE TOOL CO., LTD.

123-17, HANAMSANDAN 4BEON-RO, GWANGSAN-GU, GWANGJU, KOREA  
TEL: +82-62-951-5111 FAX: +82-62-951-0086

### SEOUL OFFICE

46, BANGBAE-RO, SEOCHO-GU, SEOUL, KOREA  
TEL: +82-2-523-7766 FAX: +82-2-523-2867

### USA

#### HWACHEON MACHINERY AMERICA, INC.

555 BOND STREET, LINCOLNSHIRE, ILLINOIS, 60069, USA  
TEL: +1-847-573-0100 FAX: +1-847-573-9900

### SINGAPORE

#### HWACHEON ASIA PACIFIC PTE. LTD.

21 BUKIT BATOK CRESCENT, #08-79 WCEGA TOWER,  
658065, SINGAPORE  
TEL: +65-6515-4357 FAX: +65-6515-4358

### VIETNAM

#### HWACHEON MACHINE TOOL VIETNAM CO., LTD.

UNIT 507, 5TH FLOOR, LOT T2-4, D1 ROAD, SAIGON HI-TECH PARK,  
TAN PHU WARD, DISTRICT 9, HO CHI MINH CITY, VIETNAM  
TEL: +84 (0)28-2253-2613 FAX: +84 (0)28-2253-2614

### GERMANY

#### HWACHEON MACHINERY EUROPE GMBH

JOSEF-BAUMANN STR. 25, 44805, BOCHUM, GERMANY  
TEL: +49-234-912-816-0 FAX: +49-234-912-816-60

### INDIA

#### HWACHEON MACHINE TOOL INDIA PTE. LTD.

103, GULMOHAR CENTRE POINT, 34/A, WADGAON SHERI,  
PUNE 411 014, INDIA  
TEL: +91-20-6560-0168

### CHINA

#### HWACHEON MACHINE TOOL CHINA CO., LTD.

B03A LIANGUAN JUHE INTERNATIONAL HARDWARE CITY, NO.  
143 ZHENANZHONG ROAD, JINXIA, CHANGAN TOWN,  
DONGGUAN CITY, GUANDONG PROVINCE, CHINA #523852  
TEL: +86-769-8932-0601 FAX: +86-769-8932-0602