

CNC Spindle Slide
Precision Lathe

XXW series



TAKAMAZ

CNC **2**-Spindle **2**-Slide Precision Lathe

XW series

*Full Lineup of **2**-Spindle and **2**-Slide Lathe Machines!*



From the original spindle parallel structure, a high rigidity, compact and high precision design is achieved. This qualifies as an expert model for durability on mass production system.

Simultaneous same process machining







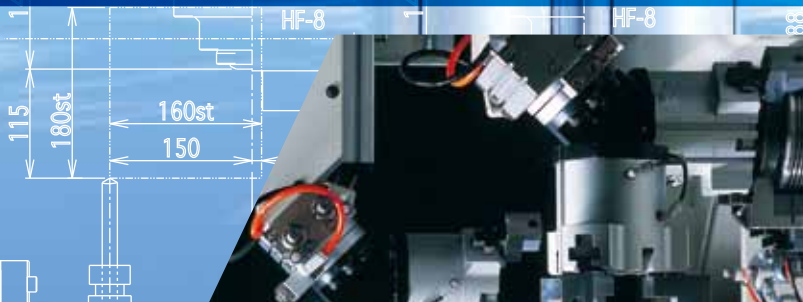



“Work in process” is no longer in inventory. The loader is equipped with a 3-axis servo that is realized by a flexible line structure that leads to reduction of the production line.

Simultaneous machining of both sides of the part



Depending on the production requirements, separate left and right cutting is possible.

Independent production form

	Chuck size	Type		
XW-30	3 Inch	 Gang Type	The best machine for small production!	P3–P4
XW-30PLUS	4 Inch	 Gang Type	Achieving high-speed, high-accuracy machining!	P3–P4
XW-60	6 Inch	 8 Drum Type	Medium-sized machine boasting high productivity!	P5–P6
XW-60M	6 Inch	 10 Drum Type	Achieving versatile machining by mounting power tools!	P5–P6
XW-130	8 Inch	 8 Drum Type	Fastest loading time in its class	P7–P8
XW-130M	8 Inch	 10 Drum Type	Achieving high productivity with powerful milling!	P9–P10
XW-200	10 Inch	 8 Drum Type	Long-awaited machine accepting 10-inch chucks!	P11–P12
XWT-10	10 Inch	 10 Drum Type	Upgraded machine with two 10-station turrets!	P13–P14



※The photo shows the XW-30PLUS.

CNC 2-Spindle 2-Slide Precision Lathe

XW-30/30

Chuck size 3 / 4 Inch

PLUS

※The XW-30 accepts 3-inch chucks only.



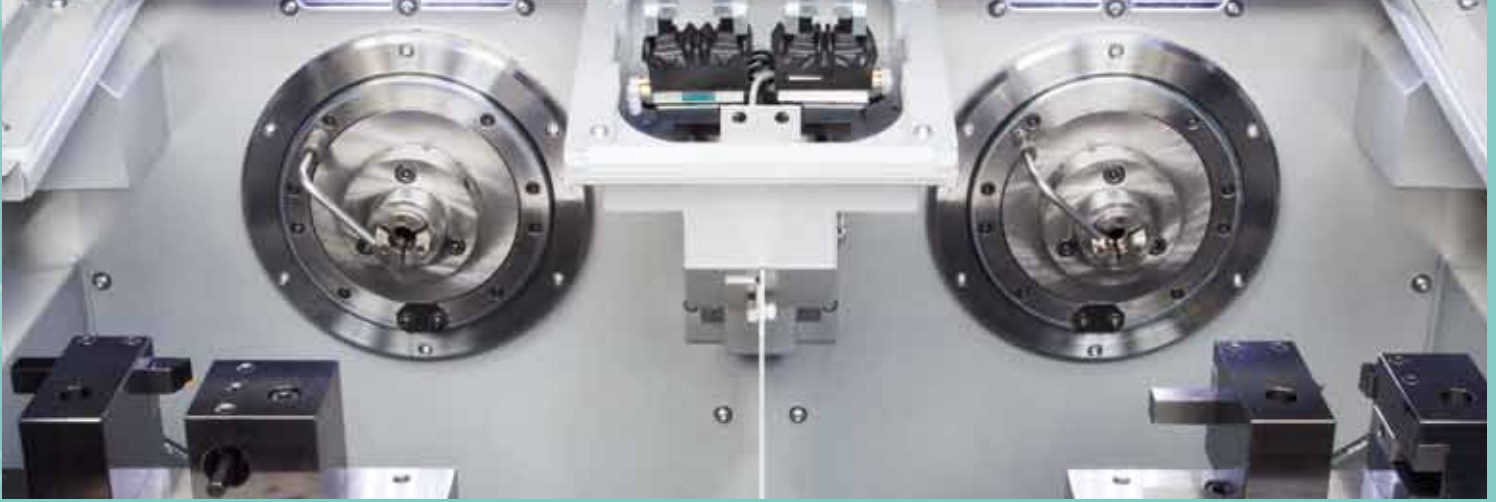

High-speed, high-accuracy machining achieved in an elegant, compact body!

Incorporating a new-type spindle unit (XW-30PLUS)

A high-efficiency motor with an output of 5.5/7 kW is adopted as the built-in motor. The unit is compatible with chucks up to 4 inches, and a hydraulic cylinder can also be equipped as an option to enable stable mass production machining of workpieces that require a strong gripping force. The reviewed cooling circuit has made the oil controller that used to be essential for short-cycle machining unnecessary*, reducing the cost and space requirements.

*An oil controller is still required with some specifications.

Pursuing high precision cutting by incorporating a cooling system in the machine

Generally on a machine with 2 spindles, a heat imbalance arises in cases where different cutting is performed at the left and right sides. This leads to unstable accuracy. The XW-30 series is built with a cooling tank inside the bed for the two spindles to suppress thermal displacement, achieving stable accuracy over the long term (Patented technology).

Production improved by a high-speed loader For details, see page 13. Either a compact “ΣiW loader” or high-speed compact “ΣiWH loader” (option) can be selected. These smallest ever Takamaz loaders have been realized through a 2-stage configuration on the vertical axis. High productivity is assured by a loading time of 4 seconds with the ΣiW loader and 2 seconds with the ΣiWH loader (not including shutter operation). In addition, placing the intermediate turnover unit in the center and providing two reversing hands makes it possible to receive and deliver workpieces simultaneously without the loader going outside the machine at any time, so substantial shortening of cycle times has been achieved.

*The intermediate turnover unit is located in the center on the XW-30PLUS only.

New design with consideration for quick changeover

For setup changes, the top part of the front cover can be opened across the full width of the machine. The door opening has been scaled up from a width of 550mm on existing machines to 900mm, improving the working environment. The shutter also opens up well to the rear, allowing setup work to be performed safely and speedily.



Higher performance control system

Operating convenience is improved by making the operating box more compact than on previous models, and by adopting a touch panel.

Space-saving design and long-awaited addition of CE specifications (XW-30PLUS)

Space savings have been realized with a machine 1,340mm wide (bed width: 1,040mm), 2,120mm deep and 1,500mm high. Compliance with CE standards has been made possible too, enabling safe usage in Europe as well.

*Machines with CE specifications have different dimensions.

XW-30 Spindle power characteristic curve ■ Max.10,000min⁻¹ Standard type (AC3.7/2.2kW)

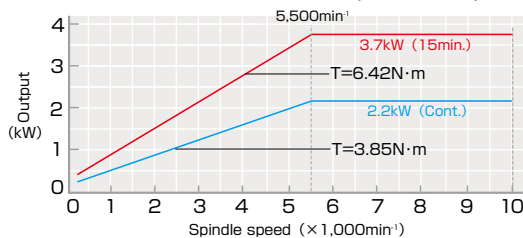

XW-30PLUS Spindle power characteristic curve ■ Max.8,000min⁻¹ Standard type (AC5.5/3.7kW)

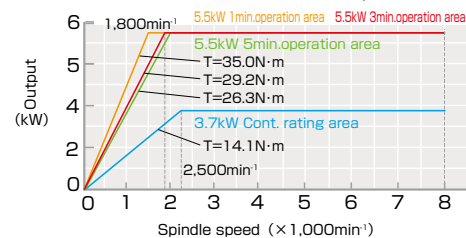



※The photo shows the XW-60M.

CNC 2-Spindle 2-Turret Precision Lathe

XW-60/60M

NEW

Chuck size 6 Inch



6-inch-chuck medium-sized machine ticking all three boxes: space savings, compound machining, and high-speed automation

Space savings in production lines

Reducing the machine width has expanded the space available for installing peripheral equipment, and also helps to shorten production lines.

Production lines: Up to 15% reduction (comparison with previous lines)

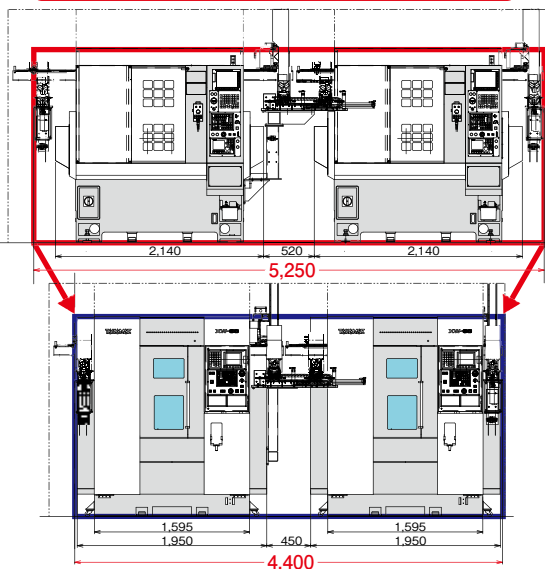

※ With 2 machines linked: shortening of 850 mm

Evolved high-speed automation system

The optimum transfer system is configured by integrating a transfer loader with the machine body, contributing to cycle time reduction. (Y-axis rapid traverse rate: 60% higher than on previous models, Loading time: 10% shorter than on previous models, Shortest cycle time for front and back machining with processes 1 and 2: 8% reduction compared to previous models)

More extensive machining possibilities

A single-tool drive system is used for power tools, which increases the transmission efficiency and improves the machining capacity. Up to 20 power tools can be mounted and with a greater mountable tool size the range of selectable tools is broadened. (60M: Power tool specifications)

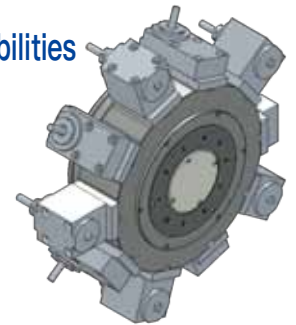

Shorter machining cycles

A 7.5/5.5 kW spindle motor is installed, and the increased power reduces spindle acceleration/deceleration times by 22% at the maximum speed (4,500 min⁻¹) compared to previous models. The reduction in non-cutting time shortens cycle times and improves productivity.

Unique thermal displacement suppression construction adopted

An original spindle base cooling system that forcibly circulates coolant (patented technology) is featured as standard, suppressing thermal displacement of the bed, minimizing changes over time, and achieving stable dimensional accuracy. In addition, a vibration damping structure that suppresses vibration by incorporating functional materials in each part of the machine (patented technology) has been adopted.

(Technology common to XW-130/XW-130M/XW-200/XWT-10)

Vibration damping function installed

For details, see page 10. (Technology common to XW-130/XW-130M/XW-200/XWT-10)

Improved operability for setup changes

For details, see page 10. (Technology common to XW-130/XW-130M/XW-200/XWT-10)

XW-60/60M Spindle power characteristic curve

■ Max.4,500min⁻¹ Standard type (AC5.5/7.5kW)

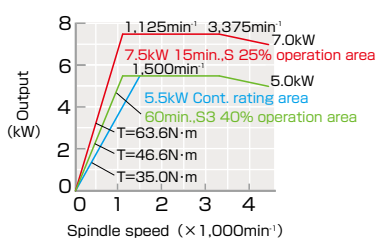

■ Max.6,000min⁻¹ Option type (AC5.5/7.5kW)

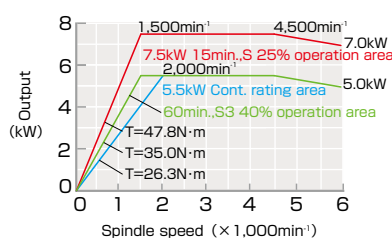

XW-60M Power tool power characteristic curve

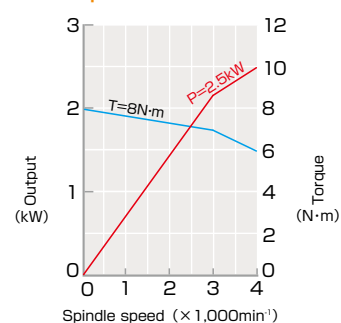

XW-130



CNC 2-Spindle 2-Turret Precision Lathe

XW-130

Chuck size 8 Inch





A 2-Spindle 2-Turret Precision Lathe with "high-speed high-power" 8-inch chuck

Loading time with a mark of fastest class at 6 seconds

The XW-130 series is equipped with a newly-developed 3-axis loader dedicated to 2-spindle configurations. High rigidity has been achieved by increasing the rack size, and higher travel speeds have been sought, resulting in the fastest loading time in its class at 6 seconds. In addition, improvement of the intermediate turnover unit has enabled workpiece delivery to be completed in one motion instead of two as was previously necessary, allowing a cycle time of only 18 seconds for processes 1 and 2 in both-side machining (Patented technology). What is more, one of the parallel loader hands has been given an independent drive function, and a configuration that minimizes interference with the stocker, washer unit, etc., during delivery has been adopted.



High-speed shutter installed

The shutter that opens and closes when the loader enters has been made even faster. The combination of solenoid valve control with the ideal cylinder has cut the operating time of previous models in half, to under 0.5 seconds for both opening and closing operations.

Ease of maintenance

For cutting inside the machine, there is no exposure of the slide wipers. Therefore countermeasure for hot chip is perfect. In addition, because of the chip conveyor, stagnation of the chip does not occur directly under the spindle. Furthermore, coolant tank can be pulled out from the front of the machine, which is a structure for coolant tank easy cleaning. With complete opening of rear cover, and the piping concentrated in the machine side, it is the structure that ensures easy maintenance on the rear area of the machine.

Unique thermal displacement suppression construction adopted

For details, see page 6.
(Technology common to XW-60/XW-60M/XW-130M/XW-200/XWT-10)

Vibration damping function installed

For details, see page 10.
(Technology common to XW-60/XW-60M/XW-130M/XW-200/XWT-10)

Improved operability for setup changes

For details, see page 10.
(Technology common to XW-60/XW-60M/XW-130M/XW-200/XWT-10)

XW-130 Spindle power characteristic curve ■ Max.4,000min⁻¹ Standard type (AC11/7.5kW)

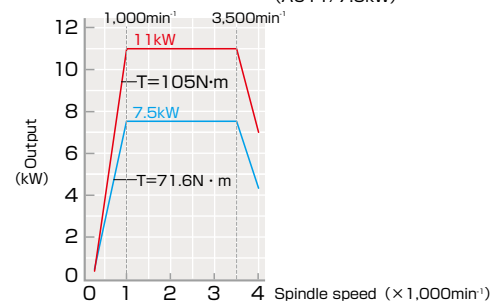



CNC 2-Spindle 2-Turret Precision Lathe

XW-130M

Chuck size 8 Inch



Support for Diverse Compound Machining Needs through Mounting of Power Tools

High productivity with powerful milling

The machine is equipped with a power tool unit suitable for 8-inch chucks. It has a maximum capacity of 20 power tools, and supports the requirements of process integration through compound machining. In addition, in-process inventory has been reduced to zero by simultaneous front and back machining, delivering high productivity.

Tool post construction enabling sustained heavy-duty cutting

A construction with square box-way slides for exceptional rigidity, and realizing little center of gravity displacement of the tool post with the X axis resting on the Z axis, is adopted for differentiation from competitors' products. This helps to resist secular changes and to dampen chattering in cutting.

(Technology common to XW-200)

Unique thermal displacement suppression construction adopted

For details, see page 6.

(Technology common to XW-60/XW-60M/XW-130/XW-200/XWT-10)

Vibration damping function installed

When finish machining, commands to ameliorate the effects of vibrations due to the operation of the spindle at the other side, or reduce them to zero, are available. They can be selected and programmed in various cases (prioritizing accuracy, prioritizing cycle time).

(Technology common to XW-60/XW-60M/XW-130/XW-200/XWT-10)

Improved operability for setup changes

A low center of gravity construction with the spindle center height restricted to 1,000 mm allows chucks and workpieces to be changed in a comfortable posture. The work can also be done in a bright machine interior since overhead lighting is featured as standard, and this helps to shorten working times and greatly improve operating efficiency. In addition, the adoption as standard of a swiveling operation panel and a pendant operation panel for the transfer loader enables simple and accurate teaching.

(Technology common to XW-60/XW-60M/XW-130/XW-200/XWT-10)



XW-130M Spindle power characteristic curve ■ Max.4,000min⁻¹ Standard type (AC11/7.5kW)

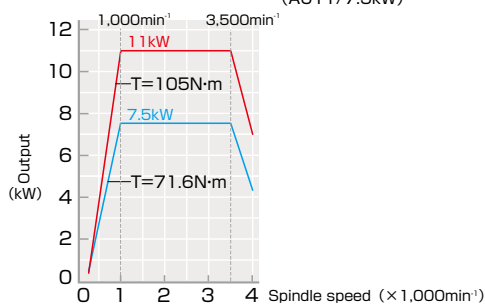

XW-130M Power tool power characteristic curve ■ Max.4,000min⁻¹ Standard type (AC3.7/2.2kW)

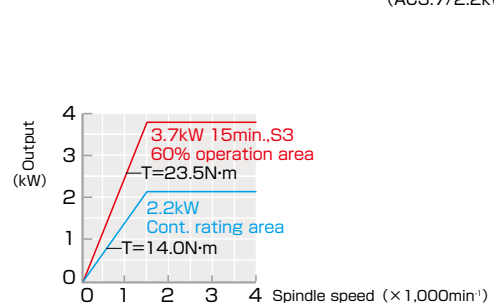

XW-200



CNC 2-Spindle 2-Turret Precision Lathe

XW-200

Chuck size 10 Inch



Long-awaited 10-inch chuck compatible machines in the XW series enable high productivity with large-diameter workpieces

Powerful heavy-duty cutting capability

The adoption of large-diameter $\phi 120\text{mm}$ bearings and an 18.5/15 kW motor has realized stable machining of large workpieces. With stable spindle output in the mid- and low-speed ranges allow cutting across three times the cutting surface area of existing models is achieved, showing their outstanding power in the heavy-duty machining of large flange-type workpieces. (Technology common to XWT-10)

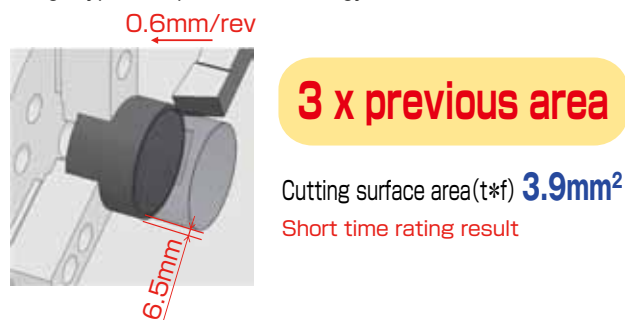

Transfer of large workpieces enabled

The largest workpieces that Takamaz machines can handle, measuring $\phi 200\text{ mm}$ and up to 8 kg, can be transferred on each side. Since hands can be folded back in addition to being turned, workpieces arranged in a line can be picked up easily without interfering with the loader on one side. (Technology common to XWT-10)

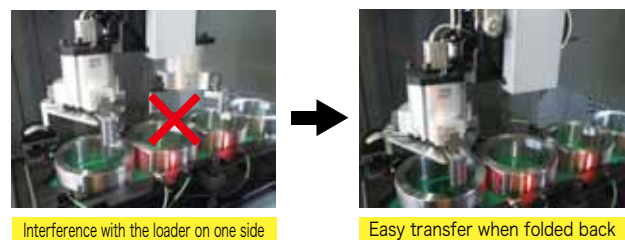

Intermediate turnover unit that can handle large-diameter workpieces

A high-speed shutter with patented technology is used, cutting the operating time of previous models in half, to under 0.5 seconds for both opening and closing operations, so cycle times are shortened.

Tool post construction enabling sustained heavy-duty cutting

For details, see page 10.
(Technology common to XW-130M)

Unique thermal displacement suppression construction adopted

For details, see page 6.
(Technology common to XW-60/XW-60M/XW-130/XW-130M/XWT-10)

Vibration damping function installed

For details, see page 10.
(Technology common to XW-60/XW-60M/XW-130/XW-130M/XWT-10)

Improved operability for setup changes

For details, see page 10.
(Technology common to XW-60/XW-60M/XW-130/XW-130M/XWT-10)

XW-200 Spindle power characteristic curve

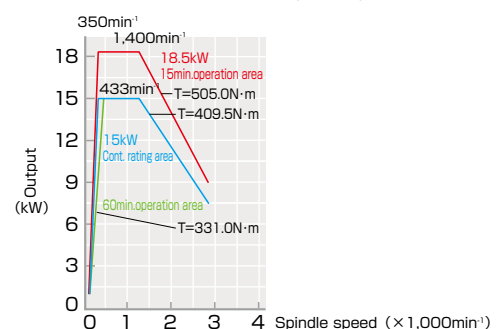

XWWT-10



CNC 2-Spindle 2-Turret Precision Lathe

XWWT-10 NEW

Chuck size 10 Inch



Upgraded machine realizing the largest OD turning range of the XW series!

Equipped with 10-station turrets

With two 10-station turrets, tool capacity is increased, boosting production efficiency.

The largest turning range of the XW series

The maximum turning range in the XW series is secured, making it possible to handle workpieces that require simultaneous deep ID and OD turning, such as differential cases and brake calipers.

You can also take advantage of the spacious machine interior to mount chucks of various designs.

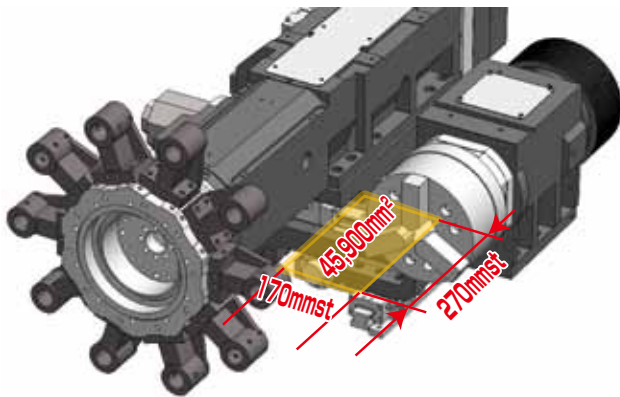

Improved chip disposal

In addition to chip flushing inside the machine, a chip flushing circuit is installed behind the cover under the door to prevent chip retention and promote a straight drop of chips into the chip conveyor (optional) below the spindle.

Powerful heavy-duty cutting capability

For details, see page 12.

(Technology common to XW-200)

Transfer of large workpieces enabled

For details, see page 12.

(Technology common to XW-200)

Unique thermal displacement suppression construction adopted

For details, see page 6.

(Technology common to XW-60/XW-60M/XW-130/XW-130M/XW-200)

Vibration damping function installed

For details, see page 10.

(Technology common to XW-60/XW-60M/XW-130/XW-130M/XW-200)

Improved operability for setup changes

For details, see page 10.

(Technology common to XW-60/XW-60M/XW-130/XW-130M/XW-200)

XWT-10 Spindle power characteristic curve ■ Max.2,800min⁻¹ Standard type (φ 120 spindle AC18.5/15kW)

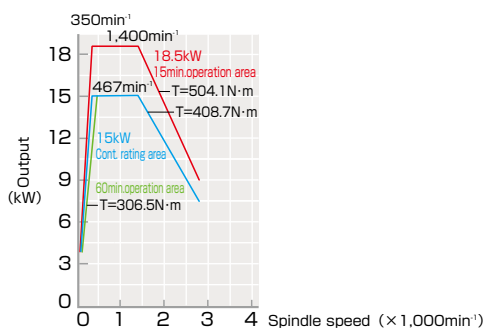

■ Max.4,000min⁻¹ Option type (φ 120 spindle AC18.5/15kW)

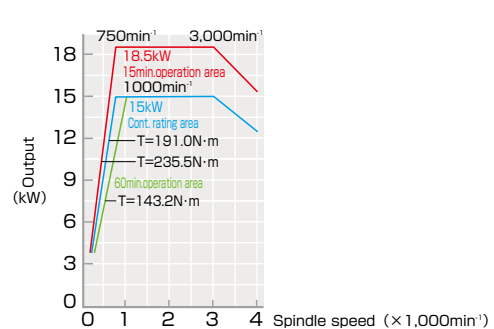

Equipped with the [Speed] and [Small Footprint] Servo Loader, “Σi Series”

As a result of machine body and loader integrated as one unit, superiority in design balance is accomplished as well as high productivity and space savings, and with after-sale service by **TAKAMAZ**, will benefit the customer on different aspects.

- ◆The largest three-axis control, setup is easy and can be done quickly.
- ◆Depending on the cutting time, it is possible to equip the machine with 1 or 2 loaders.
- ◆In each point, it is possible to set the interlock to prevent accidental collision.
- ◆All database, the servo parameter, the data tables, and timer setting can be uploaded and downloaded to and from the memory card.



Loader transfer capacity

Item	Unit	XW-30/30PLUS		XW-60/60M		XW-130	XW-130M/200	XW-200	XWT-10
		ΣIW30*	ΣIW30H*	ΣIGTH60	ΣIGTH60(High speed type)	ΣIGTH150		ΣIGTH200	
Loader Model		ΣIW30*	ΣIW30H*	ΣIGTH60	ΣIGTH60(High speed type)	ΣIGTH150		ΣIGTH200	
Number of axes	axes	2			3				
Loading Time (Reference)	sec.	4	2	6	2	6		7	
Transport Work Dimension	Diameter x Length (Reference)	φ30×40		φ60×60	φ55(φ60)×60	φ150×50		φ200×120	φ200×220
	Weight	0.3(One side)		1.0(One side)		3.0(One side)		8.0(One side)	
Shoulder (Traverse axis : Z)	Drive System	Servomotor							
	Stroke	Depends on specifications							
	Rapid Traverse Rate	m/min	80	150	120		170		100
Forward/ Backward axis : X	Drive System	Servomotor							
	Stroke	—		200		235			
	Rapid Traverse Rate	m/min	—		45		35		30
Arm (Vertical axis: Y)	Drive System	Servomotor							
	Stroke	mm	250	240	590		690	760	780
	Rapid Traverse Rate	m/min	80	150	125	170	125		80
Hand	Drive System	Air cylinder							
	Angle	deg.	—			90			
	Jaw Stroke	mm	9(One side)	—	10(One side)		16(One side)		12(One side)
Hand Type		Parallel Hand	Pivoting open/close hand	ΣIGTH dedicated L Hand					

※The loader installed on the XW-30 is the ΣW30/ΣW30H.

※The loader for the XW-30PLUS with CE specifications is the ΣW30/ΣW30H.

The loading time, transport and work dimensions are the indicators.

Different Varieties of Loader Hand that can Handle Different Shapes of Parts

◆ Loader hands that can handle a wide range of shapes, including flange workpieces, are available.

Parallel Hand(CR)

XW-30 XW-30PLUS



ΣiGTH dedicated L Hand

XW-60 XW-60M
XW-130 XW-130M XW-200 XWT-10



Flexible Variation for Automated Large-Variety and Small-Lot Production

Machining Type / Machining Flow	Continuous Front and Rear Machining Line	Same Process Machining Line
L → R		
L ← R		
L ↻		
R ↻		
L ↔ R	—	

Automation Peripheral Devices

◆ A production line with different varieties of peripheral devices and loading variations can be designed.

In / Out Stocker



In / Out Conveyor



Auto measurement unit



External turning device

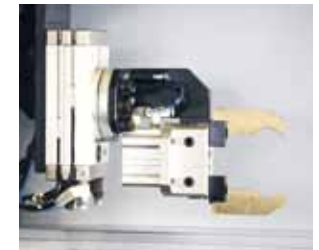

Quality / Environment Control Unit



● **Signal Tower**
The solid and flashing lights for the operating conditions.



● **Cleaning unit**
Without operator intervention, cleaning is performed automatically.



● **Oil mist collector**
Oil mist collection facilities a clean production environment.



● **Automatic fire extinguisher**
If fire breaks out in the machine during automatic operations, fire extinguishing agent is automatically discharged.

Work Stocker / Transfer Unit



● **Tray Changer**
By stacking per pallet, scratches on parts are prevented because of better stacking resulting to an efficient form of delivery system.



● **“Rakuchin” Stocker**
Reasonably priced bucket for easy bucket transport management.



● **Elevator Hopper**
Through the stocker as first process (parts supply), the stocker is suitable for production of short delivery cycle.



● **Rotary Stocker**
The space-saving, low-cost stocker. The position can be adjusted easily according to the size of the part.

Cutting Efficiency / Chip Disposal



● **Alloyed Clamp Holder for vibration suppression**
Inhibiting the progression of wear boundary is expected to extend cutting tool life in high speed machining.



● **Chip Conveyor (Spiral Type)**
Chip disposal is done semi-automatically at a minimum space. Floor type is also available.



● **High-pressure coolant**
Constantly cooled coolant is discharged at high pressure so that the tool life is significantly prolonged.



● **Semi-dry machining**
Ultrathin, highly-lubricating vegetable coolant is applied to the correct point on the cutting edge, realizing semi-dry machining.

XW-60

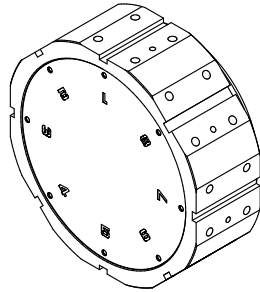

8-station turret

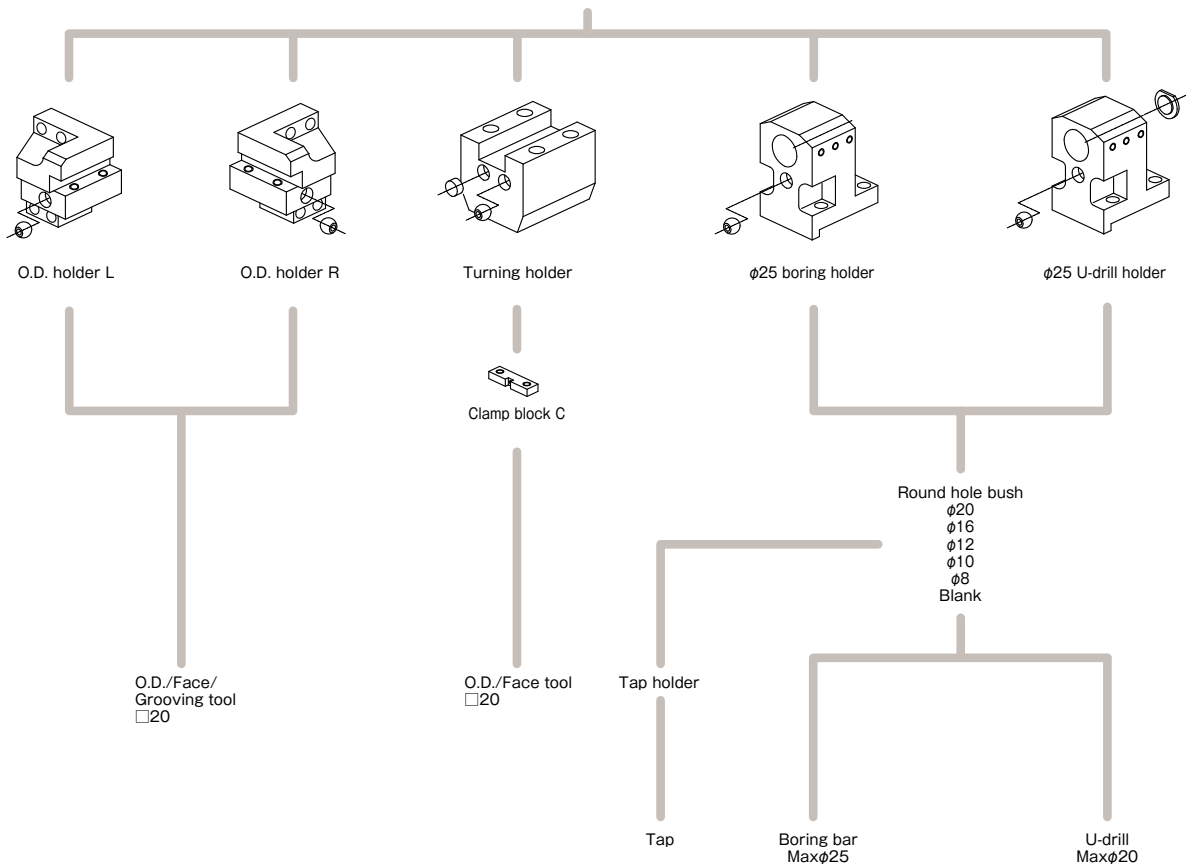

STROKE & TURRET

Stroke-Related Drawing

XW-60

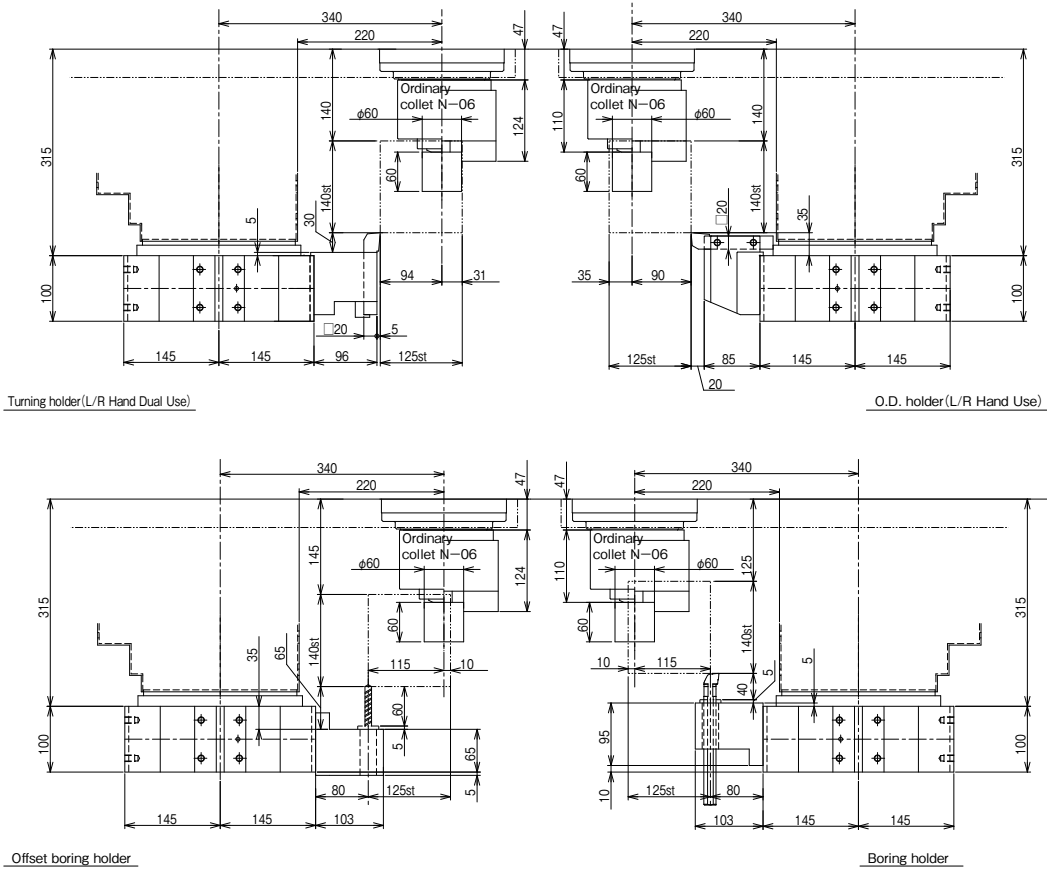

Turret Interference

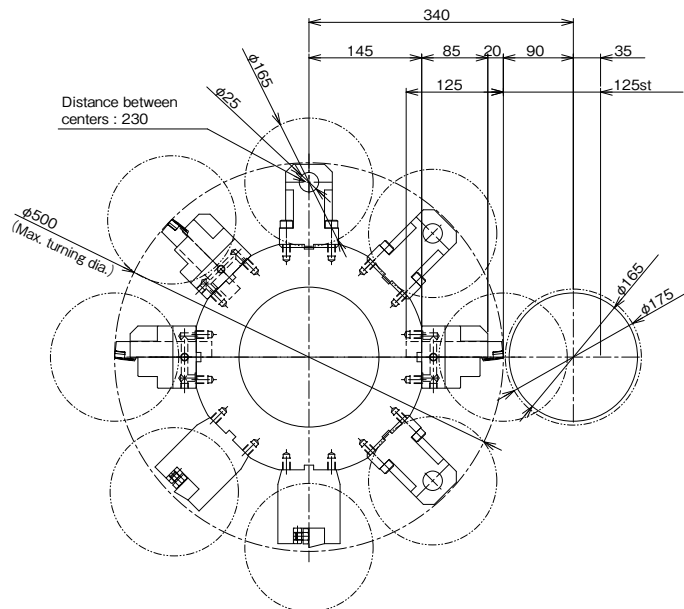

Unit(mm)

Tooling System

XW-60M

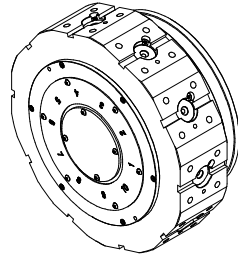

10-station turret

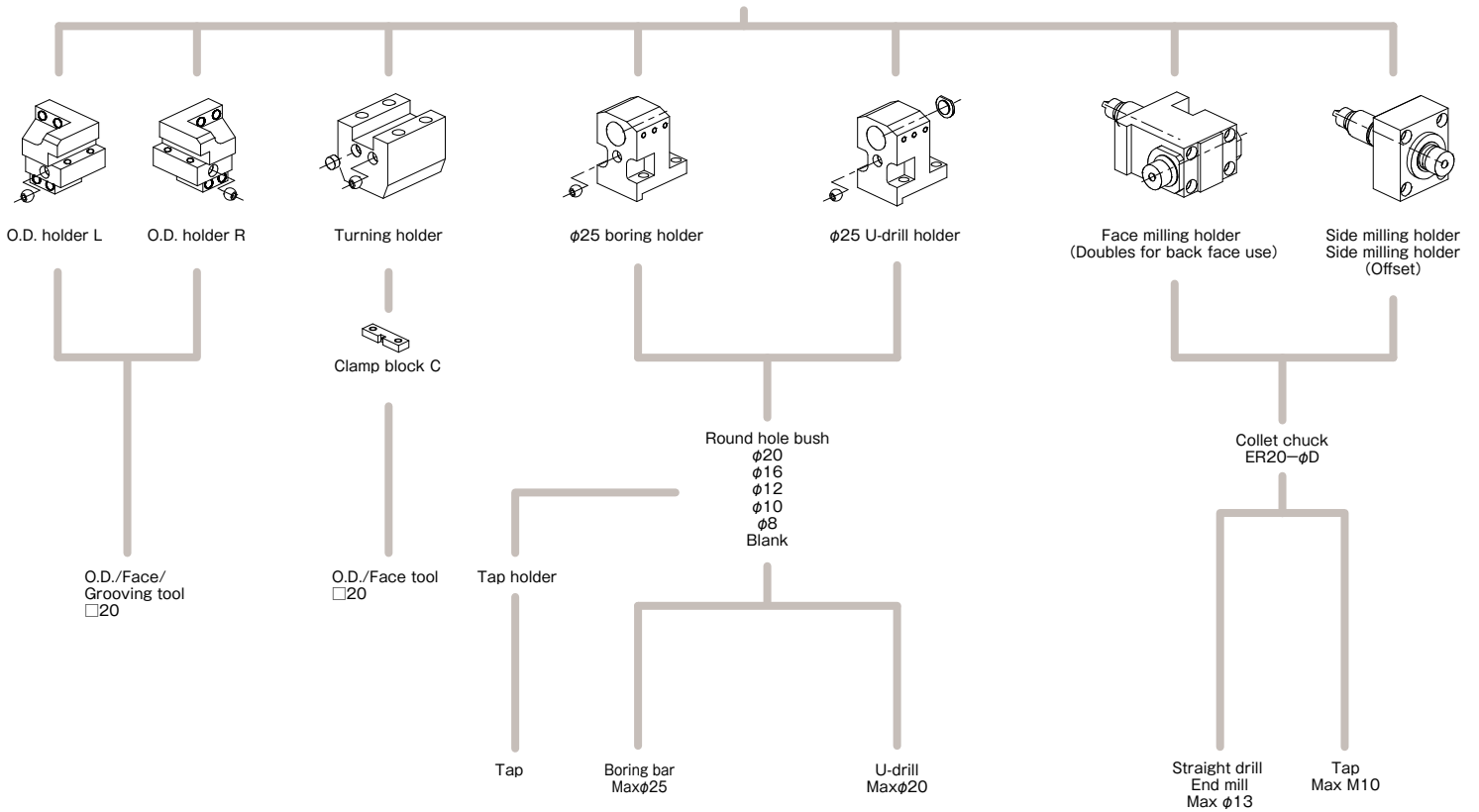

XW-130

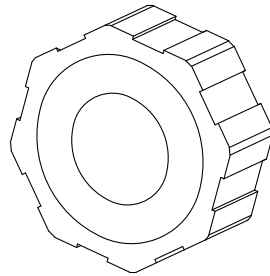

8-station turret

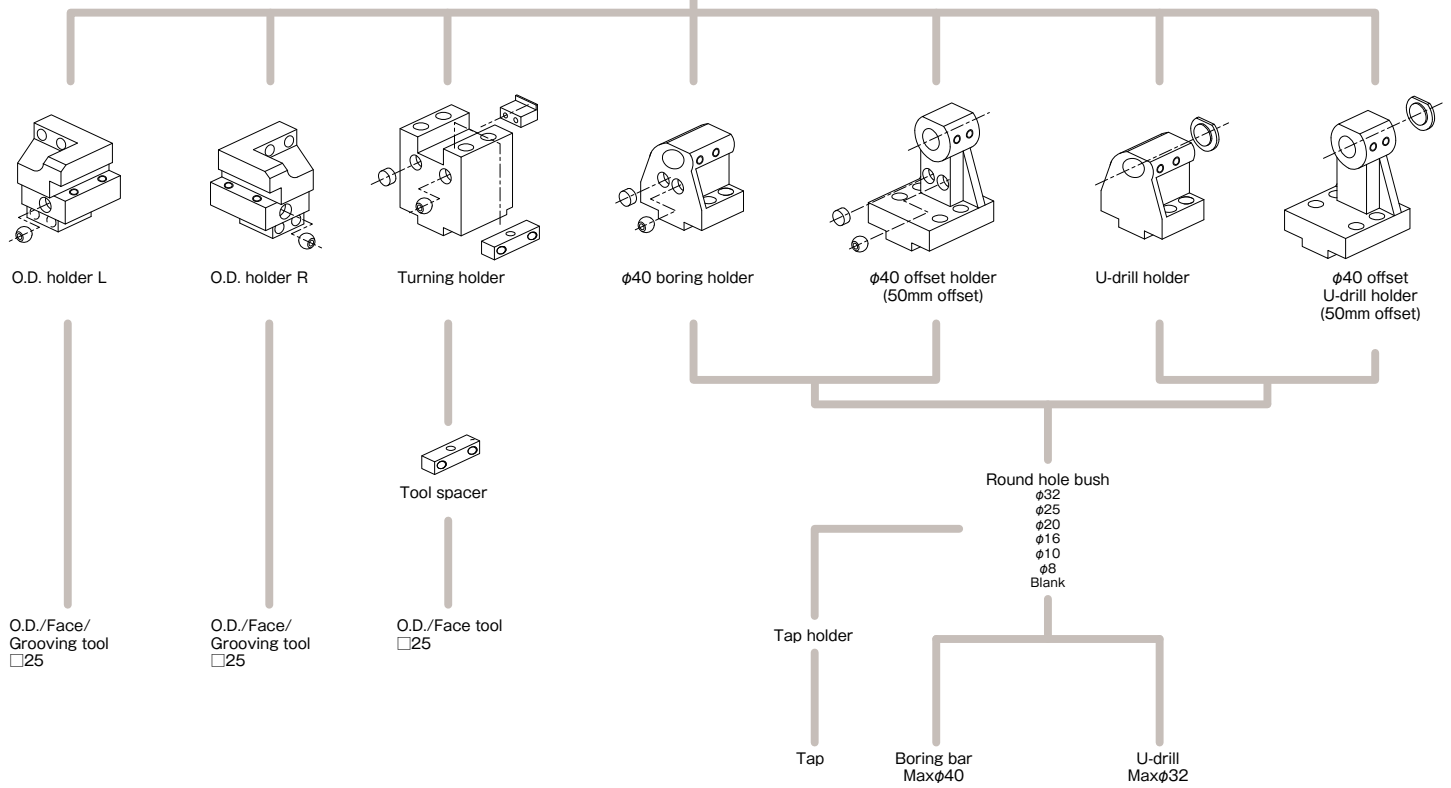

※When setup the drill, tooling space has prohibited zone.
If you need more information, please contact to TAKAMAZ.

STROKE & TURRET

Stroke-Related Drawing

XW-130

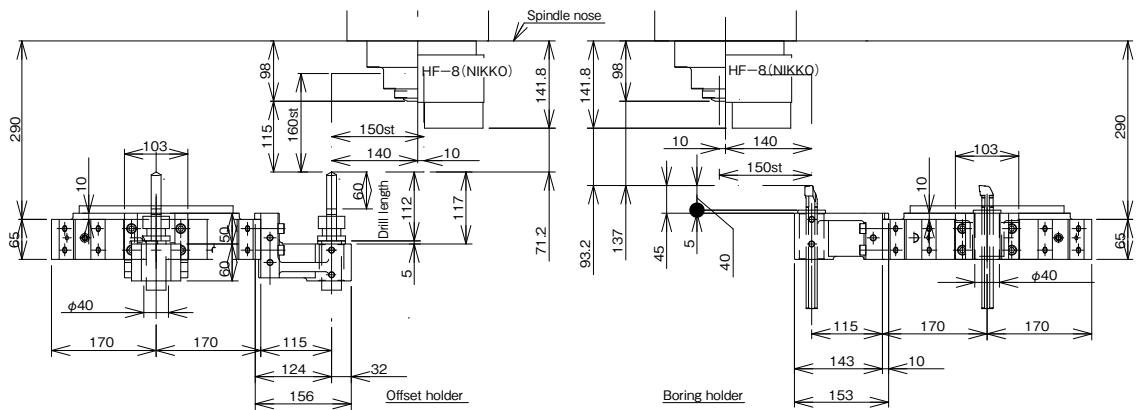
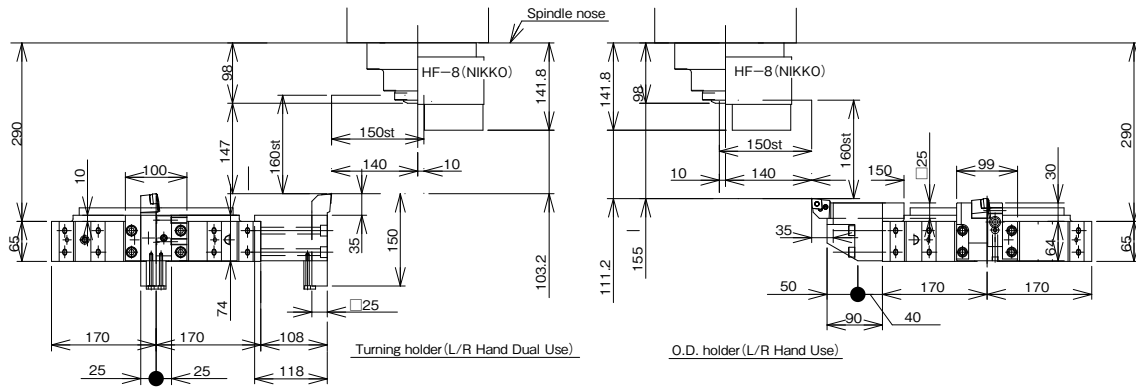

Turret Interference

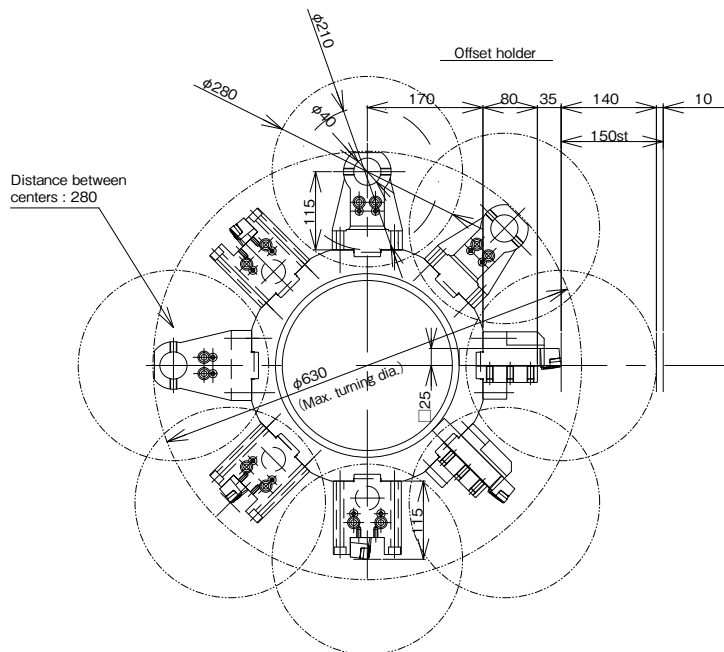

Unit(mm)

Tooling System

XW-130M

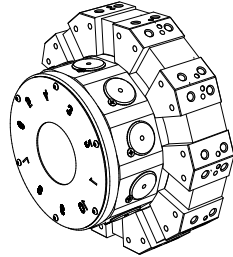

10-station turret

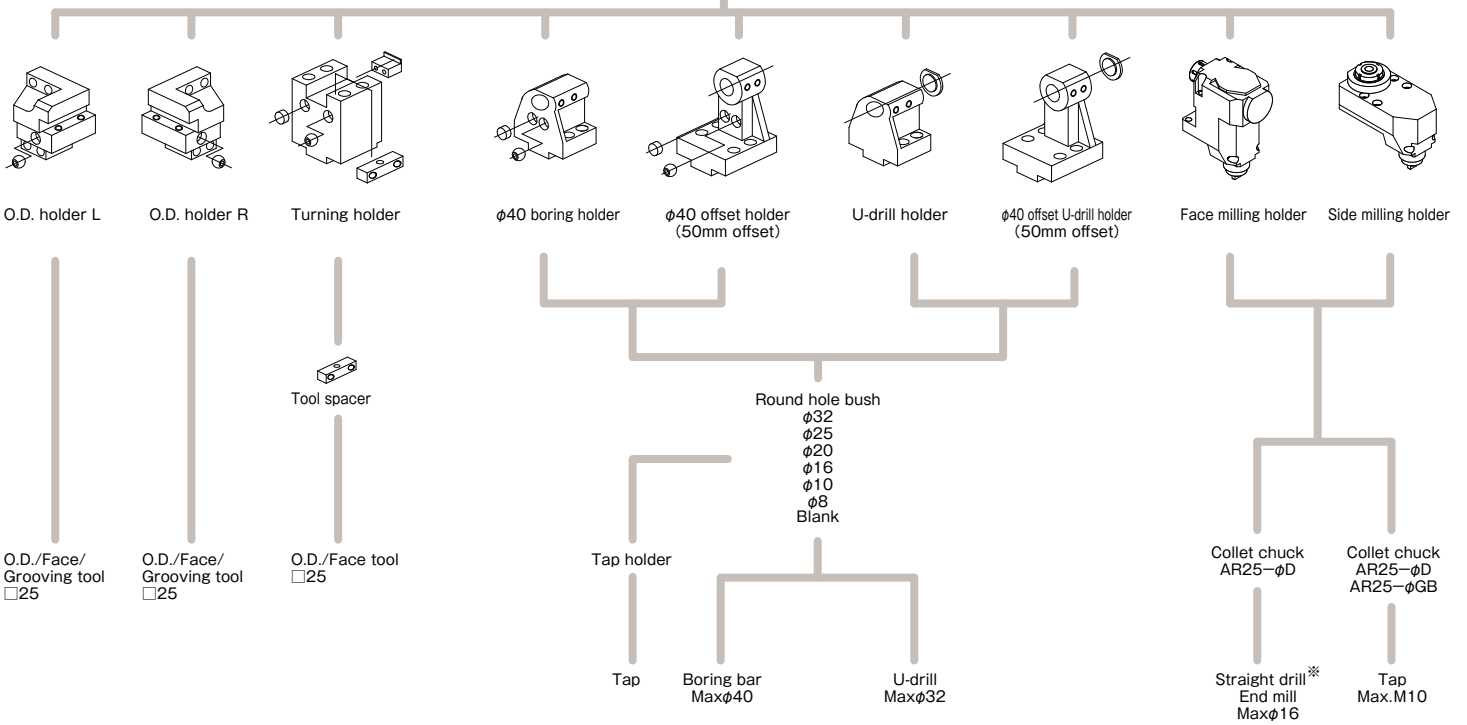

※When setup the drill, tooling space has prohibited zone.
If you need more information, please contact to TAKAMAZ.

STROKE & TURRET

Stroke-Related Drawing

XW-130M

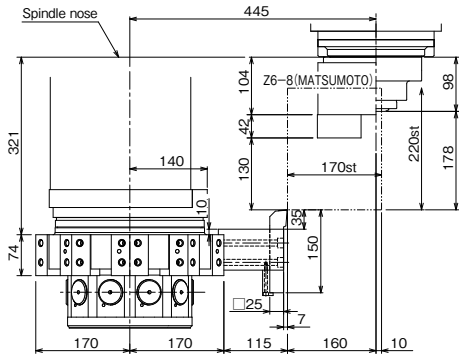

Turning holder (L/R Hand Dual Use)

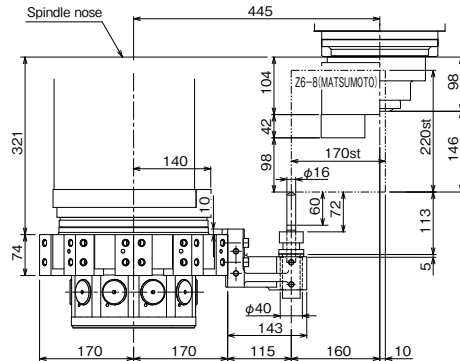

Offset boring holder

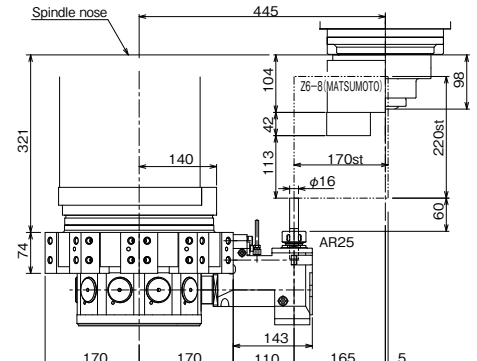

Face milling holder

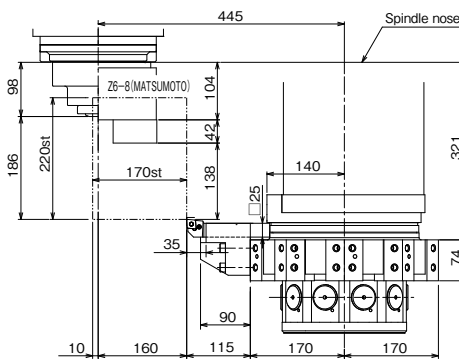

O.D. holder (L/R Hand Use)

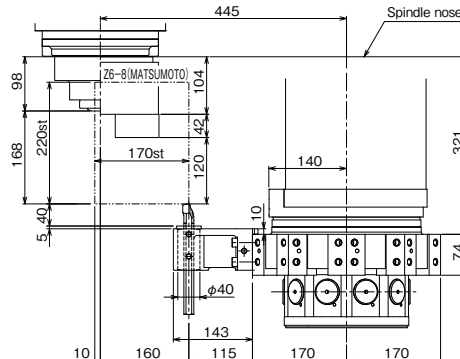

Boring holder

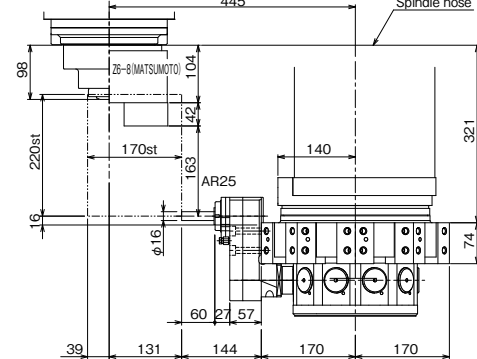

Side milling holder

Turret Interference

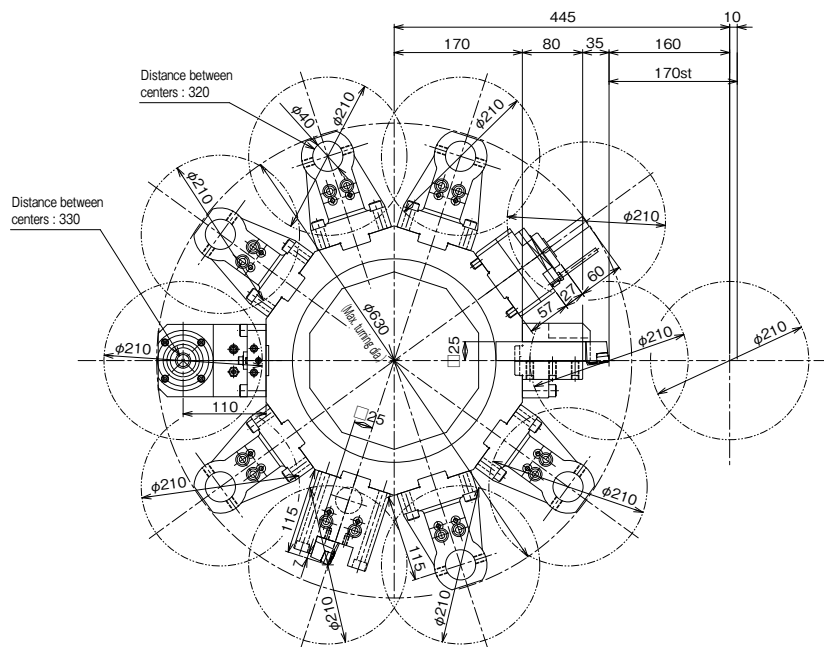

Unit (mm)

XW-200

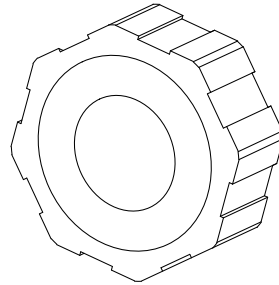

8-station turret

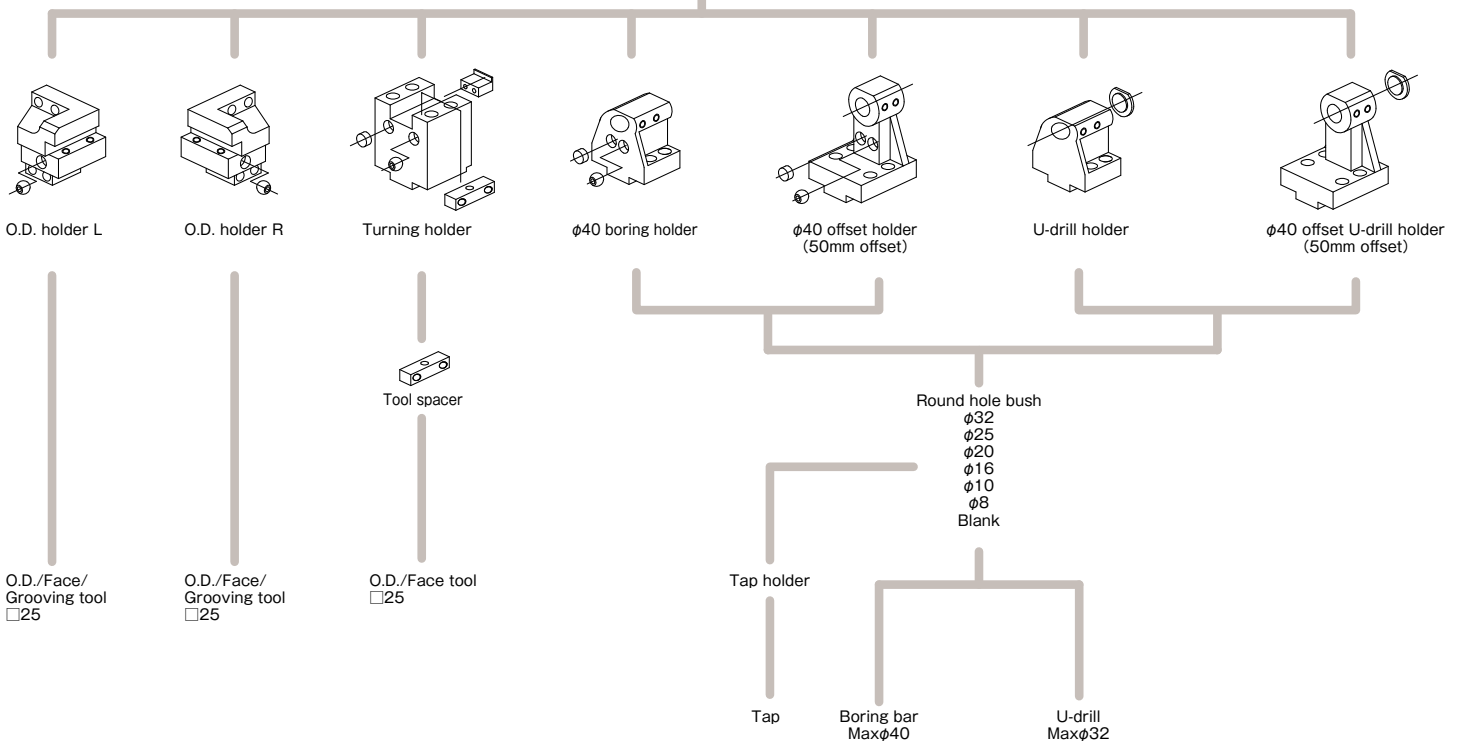

※When setup the drill, tooling space has prohibited zone.
If you need more information, please contact to TAKAMAZ.

XWT-10

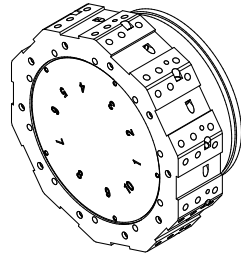

10-station turret

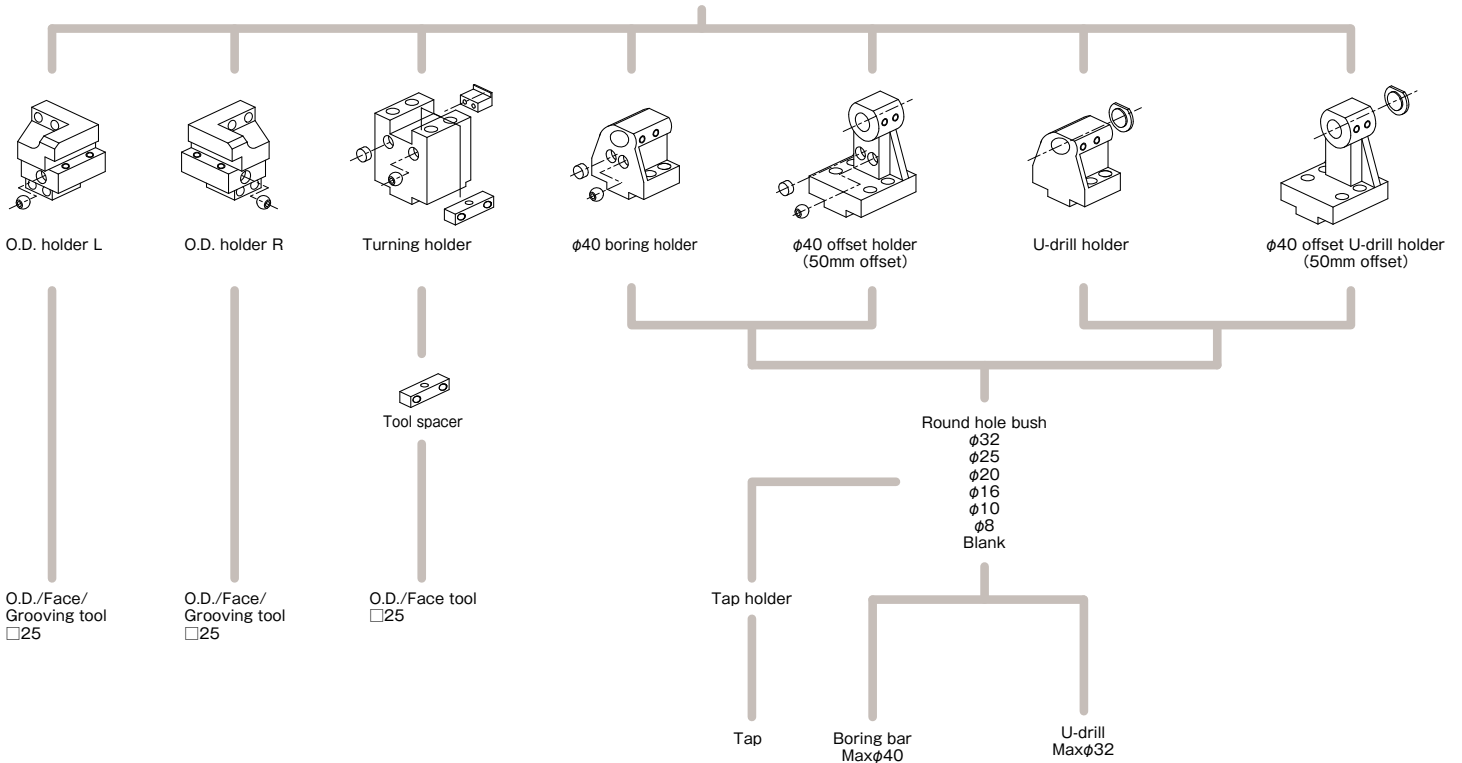

※When setup the drill, tooling space has prohibited zone.
If you need more information, please contact to TAKAMAZ.

SPECIFICATION

Machine Specifications

Item		Unit	XW-30	XW-30PLUS	XW-60	XW-60M
Capacity	Optimum turning diameter	mm	$\phi 30^{*1}$	$\phi 30$	$\phi 60$	
	Max. turning diameter	mm	$\phi 50$		$\phi 175$	
	Max. turning length	mm	50		130	
Spindle	Chuck size	inch	3: Air $\times 2$	Collet, 3,4 $\times 2$	Collet, 6 (5) $\times 2$	
	Spindle nose	JIS	A3-S2	A2-3	A2-5 (A2-4)	
	Spindle bearing I.D.	mm	$\phi 50$	$\phi 60$	$\phi 75$ ($\phi 65$)	
	Through-hole on spindle	mm	$\phi 20^{*2}$	$\phi 25$	$\phi 46$ ($\phi 36$)	
	Spindle speed	min ⁻¹	Max. 10,000 ^{*3}	Max. 8,000 (6,000 ^{*4})	Max. 4,500 (6,000)	
	Spindle indexing	deg./min	—		—	Cs-axis 18,000
Tool post	Type		Gang type $\times 2$		8-station turret $\times 2$	10-station turret $\times 2$
	Tool shank	mm	$\square 16$		$\square 20$	
	Boring holder I.D.	mm	$\phi 25$		$\phi 25$	
	Max. stroke	mm	X:160 Z:200	X:160 Z:230	X:125 Z:140	
	Rapid traverse rate	m/min	X:12 Z:15	X:12 Z:20	X:21 Z:18	
Power tools	Tool storage capacity	pcs.	—		—	10 (One side)
	Rotation speed	min ⁻¹	—		—	Max. 4,000
	Capacity Drill	mm	—		—	$\phi 13$
	Capacity Endmill Tap	mm	—		—	$\phi 13$ M4~M10
Motors	Spindle motor	kW	AC3.7/2.2 $\times 2$	AC5.5/3.7 $\times 2$	AC7.5/5.5 $\times 2$	
	Feed motor	kW	X:AC0.75 $\times 2$ Z:AC0.75 $\times 2$	X:AC0.4 $\times 2$ Z:AC0.75 $\times 2$	X:AC0.75 $\times 2$ Z:AC1.2 $\times 2$	
	Coolant motor	kW	AC0.18 $\times 2$	AC0.25 $\times 2$	AC0.25 $\times 2$	
	Hydraulic motor	kW	—		AC0.75 $\times 2$	
	Power tools motor	kW	—		—	
Size	L \times W \times H	mm	1,000 (1,300 ^{*5}) \times 2,000 \times 1,500	1,040 (1,340 ^{*5}) \times 2,120 \times 1,500	1,595 (1,950 ^{*5}) \times 2,005 \times 2,400 (2,650 ^{*6})	1,695 (1,950 ^{*5}) \times 2,005 \times 2,400 (2,650 ^{*6})
	Machine weight	kg	2,700	3,400	4,700	4,800
	Total electric capacity	KVA	20	20 (23 ^{*4})	28	30

*1 Some restrictions may apply depending on the chuck type or tool storage capacity. *2 Air blow only. Bar materials cannot be handled.

*3 Some restrictions may apply depending on the chucking cylinder type. *4 The value when the hydraulic unit is mounted. *5 Machine width with loader spec. *6 Height including loader.

(): Option

Standard Accessories

Item	XW-30	XW-30PLUS	XW-60	XW-60M
<input type="checkbox"/> Tool holder	4sets		—	
<input type="checkbox"/> Boring holder	—		4sets	
<input type="checkbox"/> O.D. holder	—		4sets	
<input type="checkbox"/> Collet flange	1set (TZ650)		1set	
<input type="checkbox"/> Hydraulic chucking cylinder	—	(Option)	1set	
<input type="checkbox"/> Air chucking cylinder	1set		—	
<input type="checkbox"/> TAKAMAZ loader system	—		1 unit	
<input type="checkbox"/> Spindle indexing device	—		1set (Cs-axis)	
<input type="checkbox"/> Power tools drive unit	—		1set	
<input type="checkbox"/> Spindle cooling device**	—		1set	
<input type="checkbox"/> Thread cutting unit (Including constant surface speed control)	—		1set	
<input type="checkbox"/> Front air blower	1set		(Option)	
<input type="checkbox"/> Coolant unit	1set (140lit.)	—	1set (160lit.)	—
<input type="checkbox"/> Work light	(Option)		1set	
<input type="checkbox"/> Service tool kit	—		1set	
<input type="checkbox"/> TAKAMAZ Instruction manual	—		1set	

** Oil Temperature Control Type is available as an option.

Optional Accessories

Item	XW-30	XW-30PLUS	XW-60	XW-60M
<input type="checkbox"/> Tool holders	—		○	
<input type="checkbox"/> Collet chucks	—		○	
<input type="checkbox"/> Hydraulic chucks	—	—	○	—
<input type="checkbox"/> Thermal displacement system	—		○	
<input type="checkbox"/> Chuck clamp detector (with restrictions depending on the cylinder)	○		(Standard)	
<input type="checkbox"/> High-speed loader system	—		○	
<input type="checkbox"/> Spindle indexing device	—		Electrical	
<input type="checkbox"/> Power tools	—		○	
<input type="checkbox"/> Rear chip conveyor (Floor type / Spiral type)	—		○	
<input type="checkbox"/> Front air blower	(Standard)		○	
<input type="checkbox"/> Rear air blower	—		○	
<input type="checkbox"/> Rear coolant unit	—		○	
<input type="checkbox"/> Work light	○	—	(Standard)	
<input type="checkbox"/> Signal light (1-color / 2-color / 3-color)	—		○	
<input type="checkbox"/> Automatic fire extinguisher	—		○	
<input type="checkbox"/> Automatic power shut-off device	—		○	
<input type="checkbox"/> Special color	—		○	
<input type="checkbox"/> Others**	—		○	

** For more information on attachments, consult our sales representative.

Machine Specifications

Item		Unit	XW-130	XW-130M	XW-200	XWT-10
Capacity	Optimum turning diameter	mm	φ150	φ200	φ200	
	Max. turning diameter	mm	φ280	φ320	φ320	
	Max. turning length	mm	155	220	220	270
Spindle	Chuck size	inch	Collet, 8 × 2		10 × 2	
	Spindle nose	JIS	A2-6		A2-8	
	Spindle bearing I.D.	mm	φ100		φ120	
	Through-hole on spindle	mm	φ61		φ80	
	Spindle speed	min ⁻¹	Max.4,000		Max.2,800	Max.2,800(4,000)
	Spindle indexing	deg./min	—	Cs-axis 18,000		—
Tool post	Type		8-station turret×2	10-station turret×2	8-station turret×2	10-station turret×2
	Tool shank	mm	□25		□25	
	Boring holder I.D.	mm	φ40		φ40	
	Max. stroke	mm	X:150 Z:160	X:170 Z:220	X:170 Z:220	X:170 Z:270
Power tools	Rapid traverse rate	m/min	X:24 Z:24		X:24 Z:24	
	Tool storage capacity	pcs.	—	10 (One side)	—	
	Rotation speed	min ⁻¹	—	Max.4,000	—	
	Capacity Drill	mm	—	φ16	—	
	Capacity Endmill	mm	—	φ16	—	
	Capacity Tap	mm	—	M4~M10	—	
Motors	Spindle motor	kW	AC11/7.5×2		AC18.5/15×2	
	Feed motor	kW	X:AC1.2×2 Z:AC1.8×2		X:AC1.2×2 Z:AC1.8×2	
	Coolant motor	kW	AC0.25 × 2		AC0.25 × 2	
	Hydraulic motor	kW	AC0.75 × 2		AC0.75 × 2	
	Power tools motor	kW	—	AC3.7/2.2		—
Size	L×W×H	mm	1,890 (2,250 ^{※1}) × 2,140 × 2,050 (2,925 ^{※2})	1,990 (2,350 ^{※1}) × 2,330 × 2,400 (3,080 ^{※2})	1,990 (2,350 ^{※1}) × 2,330 × 2,400 (3,080 ^{※2})	2,030 (2,350 ^{※1}) × 2,370 × 2,400 (3,080 ^{※2})
	Machine weight	kg	5,600	6,900	6,900	
Total electric capacity		KVA	44	47	62	

※1 Machine width with loader spec. ※2 Height including loader.

(): Option

Standard Accessories

Item	XW-130	XW-130M	XW-200	XWT-10
<input type="checkbox"/> Boring holder			4sets	
<input type="checkbox"/> O.D. holder			4sets	
<input type="checkbox"/> Hydraulic power chuck (Solid)			1set	
<input type="checkbox"/> Hydraulic chucking cylinder			1set	
<input type="checkbox"/> Chuck clamp detector (with restrictions depending on the cylinder)	(Option)		1set	
<input type="checkbox"/> TAKAMAZ loader system			1unit	
<input type="checkbox"/> Spindle indexing device	—	1set (C-axis)		—
<input type="checkbox"/> Power tools drive unit	—	1set		—
<input type="checkbox"/> Spindle cooling device※			1set	
<input type="checkbox"/> Thread cutting unit (including constant surface speed control)			1set	
<input type="checkbox"/> Coolant unit	1set (160lit.)		1set (200lit.)	
<input type="checkbox"/> Work light			1set	
<input type="checkbox"/> Service tool kit			1set	
<input type="checkbox"/> TAKAMAZ Instruction manual			1set	

※ Oil Temperature Control Type is available as an option.

Optional Accessories

Item	XW-130	XW-130M	XW-200	XWT-10
<input type="checkbox"/> Tool holders			○	
<input type="checkbox"/> Hydraulic chucks			○	
<input type="checkbox"/> Collet chucks		○		—
<input type="checkbox"/> Thermal displacement system			○	
<input type="checkbox"/> Chuck clamp detector (with restrictions depending on the cylinder)	○		(Standard)	
<input type="checkbox"/> Spindle indexing device			Electrical	
<input type="checkbox"/> Power tools	—			—
<input type="checkbox"/> Rear chip conveyor (Floor type / Spiral type)		○		
<input type="checkbox"/> Front air blower			○	
<input type="checkbox"/> Rear air blower			○	
<input type="checkbox"/> Rear coolant unit			○	
<input type="checkbox"/> Signal light (1-color / 2-color / 3-color)			○	
<input type="checkbox"/> Automatic fire extinguisher			○	
<input type="checkbox"/> Automatic power shut-off device			○	
<input type="checkbox"/> Special color			○	
<input type="checkbox"/> Others※			○	

※ For more information on attachments, consult our sales representative.

SPECIFICATION

Controller Specifications

Item	XW-30	XW-30PLUS	XW-60	XW-60M	XW-130	XW-130M	XW-200	XWT-10
	TAKAMAZ & MITSUBISHI M70	TAKAMAZ & MITSUBISHI M70V	TAKAMAZ & FANUC Oi-TF	TAKAMAZ & FANUC Oi-TF	TAKAMAZ & FANUC Oi-TD	TAKAMAZ & FANUC Oi-TF		
Controlled axes	2axes(X,Z) ×2		3axes(X,Z,C) ×2		2axes(X,Z) ×2		3axes(X,Z,C) ×2	
Simultaneously controllable axes	Simultaneous 2 axes ×2			Simultaneous 3 axes ×2		Simultaneous 2 axes ×2		Simultaneous 3 axes ×2
Least input increment	0.0001mm(X in diameter)			0.001mm (X in diameter)				
Least command increment	X:0.00005mm Z:0.0001mm		X:0.0005mm Z:0.001mm					
Auxiliary function	M-code 3 digit							
Spindle function	S-code 5 digit			S-code 4 digit				
Tool function	T-code 2 digit			T-code 4 digit				
Tape code	EIA(RS232C)/ISO(840)automatic recognition							
Cutting feedrate	1~5,000mm/min							
Command system	Incremental/Absolute							
Linear interpolation	G01							
Circular interpolation	G02,G03							
Cutting feedrate override	0~150%							
Rapid traverse override	F0,100%							
Program number	Program file name 32 characters				4 digit		Program file name 32 characters	
Backlash compensation	0~999,999.9μm			0~9,999μm				
Program memory capacity	230Kbyte(600m) 500Kbyte(1,280m)		1Mbyte(2,560m)(Dual systems total)					
Tool offsets	80sets (Dual systems total)			128sets (Dual systems total)				
Registered programs	400pcs.(Dual systems total) 1,000pcs.(Dual systems total)		800pcs.(Dual systems total)					
Tool geometry /Wear offset	Standard							
Canned cycle	G90,G92,G94							
Radius designation on arc	Standard							
Tool offset measurement input	Standard							
Background editing	Standard							
Direct drawing dimension programming	Standard							
Custom macro	Standard							
Additional custom macro common variables	#100~#199,#500~#999							
Pattern data input	Standard(Equivalent Functions)			Standard				
Nose R compensation	G40,G41,G42							
Inch / Metric conversion	G20/G21							
Programmable data input	G10							
Run hour / Parts count display	Standard(Equivalent Functions)			Standard				
Extended part program editing	Standard							
Multiple repetitive cycle	G70~G76							
Multiple repetitive cycle II	Pocket-shaped							
Canned drilling cycle	Standard							
Chamfering / Corner R	Standard			(Option)				
Constant surface speed control	G96,G97							
Continuous thread cutting	G32							
Variable lead thread cutting	G34							
Thread cutting retract	Standard							
Clock function	Standard							
Help function	Standard							
Alarm history display	512pcs.			50pcs.				
Self-diagnosis function	Standard							
Sub-program call	Up to 8 loops			Up to 10 loops				
Decimal point input	Standard							
2nd reference point return	G30							
Work coordinate system setting	G50,G54~G59							
Rigid tapping	—		For Power Tools only		—		For Power Tools only	
Polar coordinate interpolation	—		Standard		—		Standard	
Cylindrical interpolation	—		Standard		—		Standard	
Stored stroke check 1	Standard							
Input / Output interface	Memory card,Ethernet							
Input / Output interface(RS232C)	Standard			(Option)				
Input / Output interface(USBFlash Memory)	—		Standard					
Alarm message	Standard							
Graphic display(FANUC)	Standard							
Graphic trace(MITSUBISHI)	Standard							
Spindle orientation	(Option)							
G code guidance	Standard			—				
Simple programming function(FANUC)	Standard			—				
NAVI LATHE(MITSUBISHI)	Standard			—				
Dynamic graphic display(FANUC)	Standard			(Option)		—		(Option)
Graphic check(MITSUBISHI)	Standard			(Option)		—		(Option)
Tool life management	Standard			(Option)				
Multiple M codes in one block	Max. 3			(Max. 3:Option)				
Conversational programming with graphic function	—			Standard				
Abnormal load detection	—			Standard				
Manual handle trace	—			Standard				
Automatic data backup	—			Standard				
Automatic screen deletion function	—			Standard				
TAKAMAZ management support function	—			Work/Tool counter,Tool load monitor,Other				
TAKAMAZ maintenance functions	—			Standard				
Set of Instruction Manuals for Control Device	CD-ROM		DVD-ROM(Bound:Option)		CD-ROM(Bound:Option)		DVD-ROM(Bound:Option)	

FLOOR SPACE

XW-30/XW-30PLUS

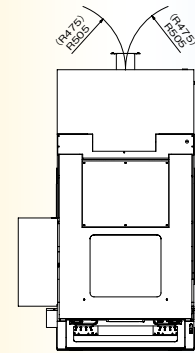
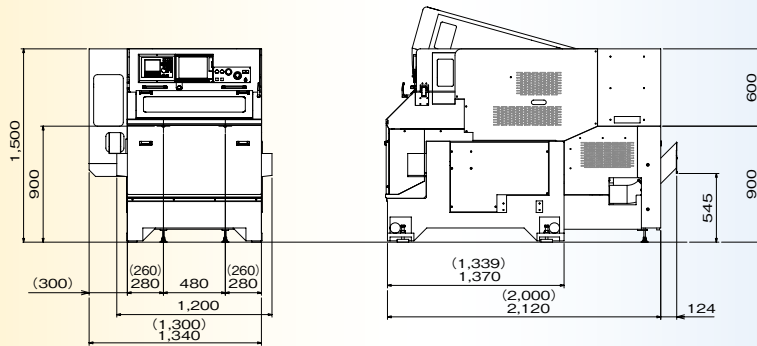

Data in parentheses is for XW-30.

XW-60/XW-60M

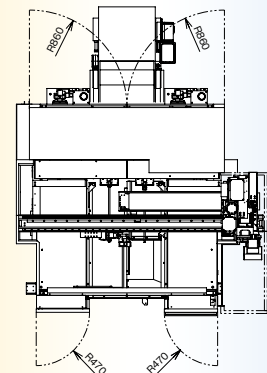
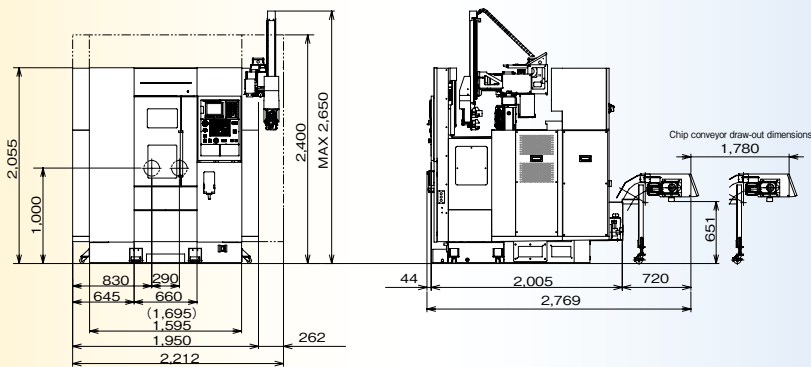

Date in parentheses is for XW-60M.

XW-130

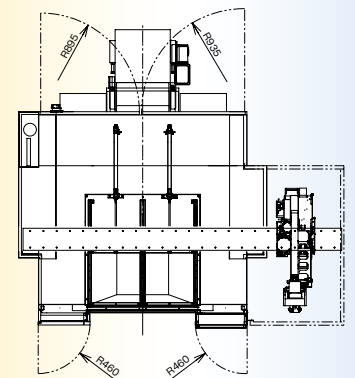
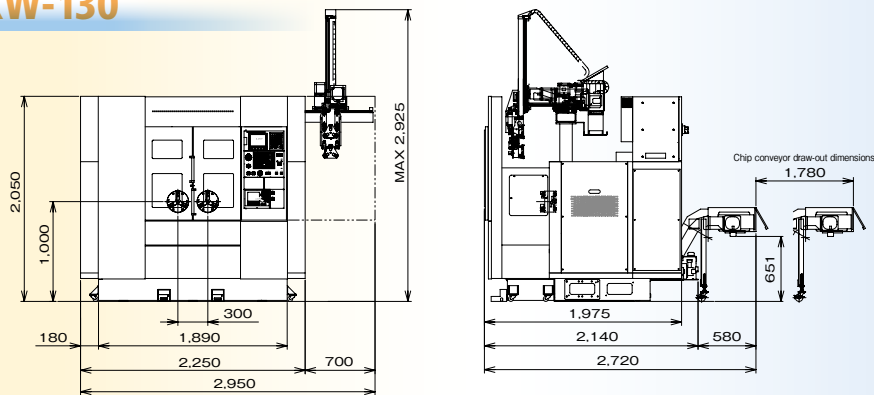

XW-130M/XW-200/XWT-10

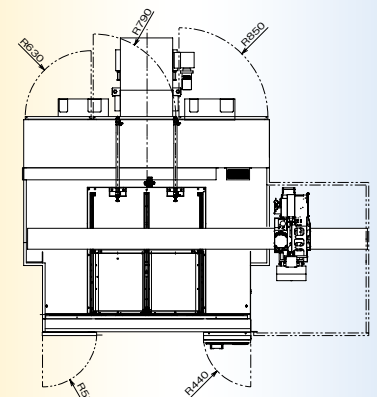
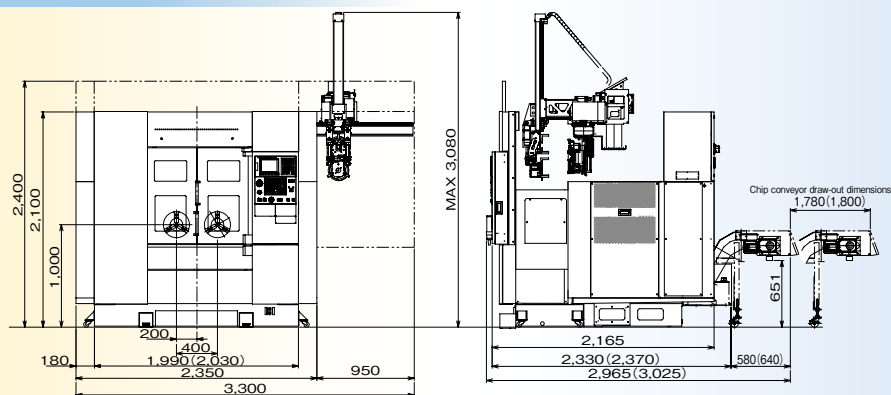

Date in parentheses is for XWT-10.

Unit (mm)



XW series

TAKAMAZ

www.takamaz.co.jp

TAKAMATSU MACHINERY CO.,LTD.

■HEAD OFFICE & PLANT
1-8 ASAHIGAOKA HAKUSAN-CITY ISHIKAWA JAPAN. 924-8558 TEL +81-(0)76-274-1403 FAX +81-(0)76-274-8530

TAKAMATSU MACHINERY USA INC.

■CHICAGO HEAD OFFICE
1280 LINDMEIER ROAD ELK GROVE VILLAGE, IL 60007 USA TEL +1-(0)847-981-8577 FAX +1-(0)847-981-8599
■CINCINNATI OFFICE
5233 MUHLHAUSER ROAD, WEST CHESTER TOWNSHIP, OH 45011 USA TEL +1-(0)513-870-9777 FAX +1-(0)513-870-0325
■GREENVILLE OFFICE
506 MATRIX PARKWAY PIEDMONT, SC 29673 USA TEL +1-(0)847-981-8577

TAKAMAZ MACHINERY EUROPE GmbH

INDUSTRIEGEBIET, DIEPENBROICH 27 D-51491 OVERATH, GERMANY
TEL +49-(0)2206-866-150 FAX +49-(0)2206-866-123

TAKAMAZ MACHINERY (HANGZHOU) CO.,LTD.

■HANGZHOU HEAD OFFICE
NO.6800, JIANGDONG 3RD ROAD, JIANGDONG INDUSTRIAL PARK, XIAOSHAN, HANGZHOU, ZHEJIANG, CHINA
TEL +86-(0)571-8287-9709 FAX +86-(0)571-8215-3732
■GUANGZHOU OFFICE
ROOM 1316, NO.2, KEHUI FOURTH STREET, NO.99 OF SCIENCE ROAD, LUOGANG DISTRICT, GUANGZHOU
TEL +86-(0)20-8210-9921 FAX +86-(0)20-8210-9921

TAKAMATSU MACHINERY (THAILAND) CO.,LTD.

■BANGKOK HEAD OFFICE
888/59 MOO 9, TAMBOL BANGPLA, AMPHUR BANGPLEE, SAMUTPRAKARN PROVINCE, THAILAND
TEL +66-(0)2-136-7831 FAX +66-(0)2-136-7834
■EASTERN SEABOARD BRANCH
848/14 MOO 3, TAMBOL BO WIN, AMPHUR SIRACHA, CHONBURI 20230
TEL +66-(0)38-182-509 FAX +66-(0)38-182-510

TP MACHINE PARTS CO.,LTD.

128/345 MOO 1 THEPARAK ROAD, BANGSAOTHONG SUBDISTRICT, BANGSAOTHONG DISTRICT, SAMUTPRAKARN
TEL +66-(0)2-706-3820 FAX +66-(0)2-706-3822

PT.TAKAMAZ INDONESIA

JL. FESTIVAL BOULEVARD BLOK AA 11 NO.30.31 GRAND WISATA TAMBUN, BEKASI 17510
TEL +62-(0)21-8261-6431 FAX +62-(0)21-8261-6430

TAKAMAZ MACHINERY MEXICO,S.A.DE C.V.

AVENIDA DE LOS INDUSTRIALES 522, LOCAL 4, INDUSTRIAL JULIAN DE OBREGON, 37290 LEON, GUANAJUATO MEXICO
TEL +52-477-784-0468

TAKAMATSU MACHINERY VIETNAM CO.,LTD

NO.25, NGUYEN LUONG BANG, TAN PHU WARD, DISTRICT 7, HO CHI MINH CITY, VIETNAM
TEL +84-(0)28-5417-3917 FAX +84-(0)28-5417-3919

Precautions Related to Foreign Exchange and Foreign Trade Control Laws

This product (machine and ancillary equipment) may fall under the category of controlled goods by the foreign exchange and foreign trade control laws.

As such, the exportation must be authorized by the Japanese government as stipulated in the laws

This product is manufactured in accordance with the regulations and standards that prevail in the country or region of destination.

The user must not export, sell, or relocate the product, to any country with different regulations or standards.

200



This brochure is made
from 60% recycled paper.

19.07.3B(0)